

# Hydraulic Pumps Mobile & Industrial T6\*R

Denison Vane Technology, fixed displacement

aerospace  
climate control  
electromechanical  
filtration  
fluid & gas handling  
**hydraulics**  
pneumatics  
process control  
sealing & shielding



ENGINEERING YOUR SUCCESS.

<b>GENERAL</b>	Features.....	3
	Instructions.....	3
	Minimum & maximum speeds.....	4
	Pressure ratings.....	4
	Priming at starting.....	4
	Minimum allowable inlet pressure.....	5
	General characteristics.....	5
	Pump selection : Routine and example.....	6
	Intermittent pressure rating.....	6
<b>INDUSTRIAL VERSION T6*R GENERAL</b>	Description.....	7
	Application advantages.....	7
	Shafts and hydraulic fluids.....	8
<b>T6CR</b>	Ordering code & Technical data.....	10
	Dimensions & Operating characteristics.....	11
<b>T6DR</b>	Ordering code & Technical data.....	12
	Dimensions & Operating characteristics.....	13
<b>T6ER</b>	Ordering code & Technical data.....	14
	Dimensions & Operating characteristics.....	15
<b>T6DCCR</b>	Ordering code & Operating characteristics.....	16
	Technical data.....	17
	Dimensions.....	18
	Porting diagrams.....	22-23
<b>T6EDCR</b>	Ordering code & Operating characteristics.....	20
	Technical data.....	21
	Dimensions.....	19
	Porting diagrams.....	22-23
<b>MOBILE VERSION T6*RM GENERAL</b>	Description.....	24
	Application advantages.....	24
	Shafts and hydraulic fluids.....	25
<b>T6CRM</b>	Ordering code & Technical data.....	26
	Dimensions & Operating characteristics.....	27
<b>T6DRM</b>	Ordering code & Technical data.....	28
	Dimensions & Operating characteristics.....	29
<b>T6ERM</b>	Ordering code & Technical data.....	30
	Dimensions & Operating characteristics.....	31
	Ordering code.....	32
	Porting combination VV.....	32
	Porting combination VP, VH & VG.....	33
	Adaptator & coupling selection.....	34
	Example.....	34

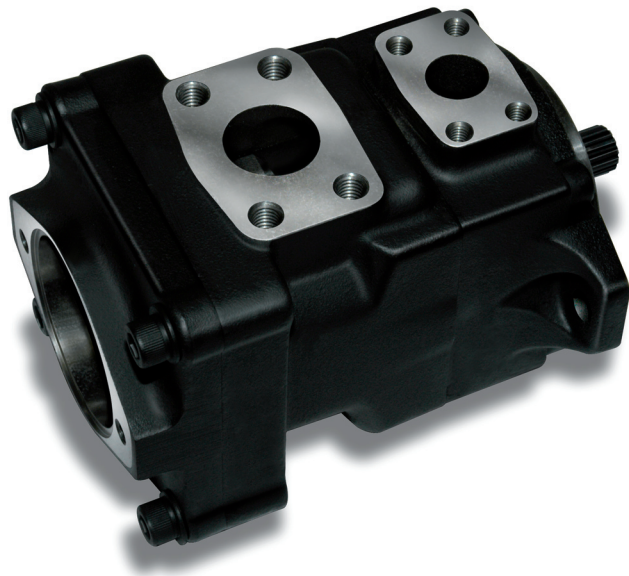

**GREATER FLOW**

Greater flow for the envelope size is achieved by increased displacement cam rings: at high permissible speeds with atmospheric inlet  
 C → 3 to 31 GPM, 10 to 100 ml/rev.  
 D → 14 to 50 GPM, 48 to 158 ml/rev.  
 E → 42 to 72 GPM, 132 to 227 ml/rev.

**HIGHER PRESSURE**

Pressure ratings up to 275 bar, which allows to reduce the size and cost of the actuators, valves and lines.

**BETTER EFFICIENCY**

Better efficiency under load which increases the productivity and reduces the heating and operating costs.

**MOUNTING FLEXIBILITY**

Single pumps : 4 positions + 4 on rear drive.  
 Triple pumps : 128 positions + 2 on rear drive.

**REAR DRIVE**

Mounting pads and couplings are fully conformable to SAE J744c and ISO 3019-1.  
 Single pumps SAE A / B / C rear adaptors.  
 SAE A / B / BB / C couplings  
 Triple pumps SAE A adaptor and coupling.

**LOWER NOISE LEVELS**

Increase the operator's safety and acceptance.

**COMPLETE CONFORMITY**

To SAE - J744c 2-bolt standards and to ISO 3019-1 in the various keyed and splined shaft options offered.

**CARTRIDGE DESIGN**

Provides for drop-in assemblies. This design permits an easy conversion or renewal of serviceable elements in minutes at minimum expense and risk of contamination. Pump rotation is easy to change by changing the position of the cam ring on the port plate dowel pin hole.

**WIDER RANGE OF ACCEPTABLE VISCOSITIES**

Viscosities from 860 to 10 cSt, (2000 to 10 cSt for Mobile), permit colder starts and hotter running. The balanced design compensates for wear and temperature changes. At high viscosity or cold temperature, the rotor to side plates gap is well lubricated and improves the mechanical efficiency.

**FIRE RESISTANT FLUIDS**

Including phosphate esters, chlorinated hydrocarbons, water glycols and invert emulsions. They may be pumped at higher pressures and with longer service life by these pumps.

**GENERAL APPLICATIONS INSTRUCTIONS**

1. Check the speed range, pressure, temperature, fluid quality, viscosity and pump rotation.
2. Check the inlet conditions of the pump, if it can accept application requirement.
3. Type of shaft : check if it can support the system's operating torque.
4. Coupling must be chosen to minimize the pump shaft load (weight, misalignment).
5. Filtration : must be adequate for lowest contamination level.
6. Environment of pump : to avoid the noise reflection, pollution and shocks.

Size	Series	Theoretical Displacement Vi ml/rev,	Minimum Speed RPM	Maximum Speed		Maximum Pressure					
				HF-0, HF-1 HF-2	HF-3, HF-4 HF-5	HF-0, HF-2		HF-1, HF-4, HF-5		HF-3	
				RPM	RPM	Int, bar	Cont, bar	Int, bar	Cont, bar	Int, bar	Cont, bar
CR CRM	*03	10,8	600 / 400	2800	1800	275	240	210	175	175	140
	*05	17,2									
	*06	21,3									
	*08	26,4									
	*10	34,1									
	*12	37,1									
	*14	46,0									
	*17	58,3									
	*20	63,8									
	*22	70,3									
	*25	79,3									
	*28	88,8		2500			210	160		160	
	*31	100,0									
DR DRM	*14	47,6	600 / 400	2500	1800	240	210	210	175	175	140
	*17	58,2									
	*20	66,0									
	*24	79,5									
	*28	89,7									
	*31	98,3									
	*35	111,0									
	*38	120,3									
	*42	136,0									
	*45	145,7									
	*50	158,0									
				2200			210	160		160	
ER ERM	042	132,3	600 / 400	2200	1800	240	210	210	175	175	140
	045	142,4									
	050	158,5									
	052	164,8									
	062	196,7									
	066	213,3									
	072	227,1									
T6DCCR	Same as			Same as		Same as					
P1	T6DR	600	T6DR			T6DR					
P2	T6CR					T6CR					
P3	T6CR					T6CR					
T6EDCR	Same as				Same as						
P1	T6ER	600	T6ER			T6ER					
P2	T6DR					T6DR					
P3	T6CR					T6CR					

\* = 0 : Industrial version

\* = B : Mobile version

HF-0, HF2 = Antiwear Petroleum Base

HF-1 = Non Antiwear Petroleum Base

HF-5 = Synthetic Fluids

HF-3 = Water in oil Emulsions

HF-4 = Water Glycols

For further information or if the performance characteristics outlined above do not meet your own particular requirements, please consult your local Parker office.

**PRIMING AT STARTING**

When the pump is set into operation for the first time, it must be primed at the lowest possible speed and pressure. When a pressure relief valve is used at the outlet, it should be backed off to minimize return pressure.

When possible, an air bleed off should be provided in the circuit to facilitate purging of system air.

Never operate the pump at maximum speed and pressure without making sure that the pump priming is completed and that the fluid is correctly deaerated (no aeration).



Cartridge		Speed RPM								Displacement
Size	Displacement	1200	1500	1800	2100	2200	2300	2500	2800	
C	*03	0,80	0,80	0,80	0,80	0,80	0,80	0,90	1,00	*03
	*05									*05
	*06									*06
	*08									*08
	*10									*10
	*12									*12
	*14									*14
	*17									*17
	*20									*20
	*22									*22
	*25									*25
	*28									*28
	*31									*31
D	*14	0,80	0,80	0,80	0,80	0,80	0,88	0,95	1,00	*14
	*17									*17
	*20									*20
	*24									*24
	*28									*28
	*31									*31
	*35									*35
	*38									*38
	*42									*42
	*45									*45
*50	*50									
E	042	0,80	0,80	0,80	0,80	0,90	1,00			042
	045									045
	050									050
	052									052
	062									062
	066									066
	072									072

Inlet pressure is measured at inlet flange with petroleum base fluids at a viscosity between 10 and 65 cSt. The difference between inlet pressure at the pump flange and atmospheric pressure must not exceed 0.2 bar to prevent aeration.

Multiply absolute pressure by 1.25 for HF-3, HF-4 fluids.  
by 1.35 for HF-5 fluid.  
by 1.10 for ester or rapeseed base.

Use highest cartridge absolute pressure for triple pumps.

**GENERAL CHARACTERISTICS**

	Mounting standard	Weight without connector and bracket - kg	Moment of inertia km <sup>2</sup> x 10 <sup>-4</sup>	SAE 4 bolts J518c - ISO/DIS 6162-1			
				Suction	Pressure		
T6CR/ T6CRM	SAE J744c ISO/3019-1 SAE B	17,0	7,6	1.1/2"	1"		
T6DR/ T6DRM	SAE J744c ISO/3019-1 SAE C	29,0	23,4	2"	1.1/4"		
T6ER/ T6ERM		39,2	51,6	3"	1.1/2"		
T6DCCR		62,0	37,4	4"	P1 1.1/4"	P2 1"	P3 1" or 3/4"
T6EDCR	250 B4HW ISO/3019-2	100,0	80,3	4"	1.1/2"	1.1/4"	1" or 3/4"

**CALCULATION**

To resolve

Volumetric displacement  $V_i$  [ml/rev.]  
 Available flow  $Q$  [l/min]  
 Input Power  $p$  [Kw]

Performances required

Requested flow  $Q$  [l/min] 60  
 Speed  $n$  [R.P.M.] 1500  
 Pressure  $p$  [bar] 150

**ROUTINE AND EXAMPLE**

Routine :

Example :

1. First calculation  $V_i = \frac{1000 Q}{n}$

$V_i = \frac{1000 \times 60}{1500} = 40 \text{ ml/rev.}$

2. Choose  $V_i$  of pump immediately greater (see tabulation)

T6CR 014  $V_i = 46 \text{ ml/rev.}$

3. Theoretical flow of this pump

$Q_{theo.} = \frac{V_i \times n}{1000}$

$Q_{theo.} = \frac{46 \times 1500}{1000} = 69 \text{ l/min}$

4. Find  $Q_{per.}$  leakage function of pressure  $Q_{per.} = f(p)$  on curve at 10 or 24 cSt

T6CR (page 10) :  $Q_{per.} = 5 \text{ l/min at 150 bar, 24 cSt}$

5. Available flow  $Q_{eff.} = Q_{theo.} - Q_{per.}$

$Q_{eff.} = 69 - 5 = 64 \text{ l/min}$

6. Theoretical input power curve

$P_{theo.} = \frac{Q_{theo.} \times p}{600}$

$P_{theo.} = \frac{69 \times 150}{600} = 17,3 \text{ kW}$

7. Find  $P_s$  hydrodynamic power loss on curve

T6CR (page 10) :  $P_s$  at 1500 R.P.M., 150 bar = 1,5 kW

8. Calculation of necessary input power

$P_{eff.} = P_{theo.} + P_s$

$P_{eff.} = 17,3 + 1,5 = 18,8 \text{ kW}$

9. Results

$V_i = 46,0 \text{ ml/rev}$   
 $Q_{eff.} = 64,0 \text{ l/min}$   
 $P_{eff.} = 18,8 \text{ kW}$  } T6CR 014

These calculation steps must be followed for each application.

**INTERMITTENT PRESSURE RATING**

T6 units may be operated intermittently at pressures higher than the recommended continuous rating when the time weighted average of pressure is less than or equal to the continuous duty pressure rating.  
 This intermittent pressure rating calculation is only valid if other parameters : speed, fluid, viscosity and contamination level are respected.  
 For total cycle time higher than 15 minutes, please consult your Parker representative.

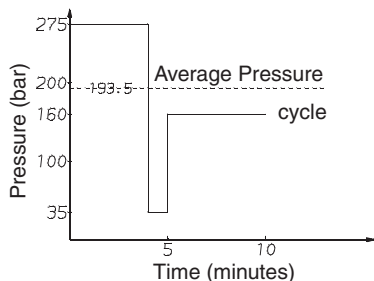

Example : T6CR - 014

Duty cycle 4 min. at 275 bar  
 1 min. at 35 bar  
 5 min. at 160 bar

$\frac{(4 \times 275) + (1 \times 35) + (5 \times 160)}{10} = 193,5 \text{ bar}$

193,5 bar is lower than 240 bar allowed as continuous pressure for T6CR - 014 with HF-0 fluid.

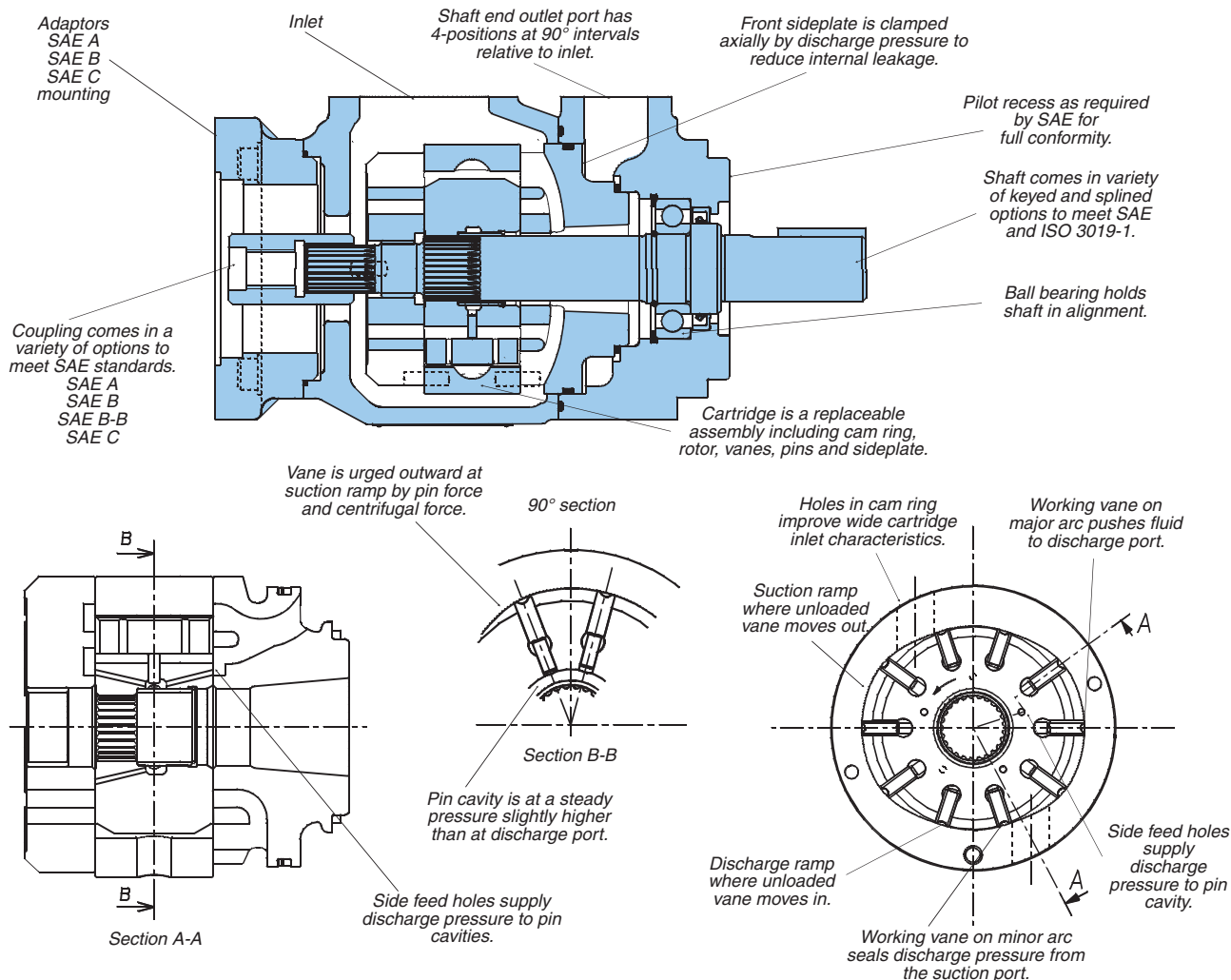

**APPLICATION ADVANTAGES**

- The high pressure capability up to 275 bar, in the small envelope, reduces the installation costs and provides an extended life at reduced pressure.
- The high volumetric efficiency, typically 94%, reduces the heat generation, and allows speeds down to 600 RPM at full pressure.
- The high mechanical efficiency, typically 94%, reduces energy consumption.
- The wide speed range from 600 RPM to 2800 RPM, combined with large size cartridge displacements, will optimize operation for the lowest noise level in the smallest envelope.
- Operating the pump at a high viscosity (up to 860 cSt) and/or at low speed (down to 600 RPM) allows applications in cold environments with minimum energy consumption and without seizure risk.
- The low ripple pressure  $\pm 2$  bar reduces the piping noise and increases the life time of other components in the circuit.
- The high resistance to particle contamination because of the double lip vane increases the pump life.
- The large variety of options (cam displacement, shaft, porting) allows customized installation.

**RECOMMENDED FLUIDS**

Petroleum based antiwear R & O fluids.  
 These fluids are the recommended fluids for T6 series pumps. Maximum catalog ratings and performance data are based on operation with these fluids. These fluids are covered by Denison fluids HF-0 and HF-2 specification.

**ACCEPTABLE ALTERNATE FLUIDS**

The use of fluids other than petroleum based antiwear R & O fluids requires that the maximum ratings of the pumps will be reduced. In some cases the minimum replenishment pressures must be increased. Consult specific sections for more details.

**VISCOSITY**

Max (cold start, low speed & pressure) _____	860 mm <sup>2</sup> /s (cSt)
Max (full speed & pressure) _____	108 mm <sup>2</sup> /s (cSt)
Optimum (max. life) _____	30 mm <sup>2</sup> /s (cSt)
Min (full speed & pressure for HF-1, HF-3, HF-4 & HF-5 fluids) _____	18 mm <sup>2</sup> /s (cSt)
Min (full speed & pressure for HF-0 & HF-2 fluids) _____	10 mm <sup>2</sup> /s (cSt)

**VISCOSITY INDEX**

90° min. higher values extend range of operating temperatures.  
 Maximum fluid temperature (θ) °C

HF-0, HF-1, HF-2 _____	+ 100° C
HF-3, HF-4 _____	+ 50° C
HF-5 _____	+ 70° C
Biodegradable fluids (esters & rapeseed base) _____	+ 65° C

Minimum fluid temperature (θ) °C

HF-0, HF-1, HF-2, HF-5 _____	- 18° C
HF-3, HF-4 _____	+ 10° C
Biodegradable fluids (esters & rapeseed base) _____	- 20° C

**FLUID CLEANLINESS**

The fluid must be cleaned before and during operation to maintain the contamination level of NAS 1638 class 8 (or ISO 19/17/14) or better. Filters with 25 micron (or better, β10 ≥ 100) nominal ratings may be adequate but do not guarantee the required cleanliness levels. Suction strainers must be of adequate size to provide the minimum inlet pressure specified. 100 mesh (150 micron) is the finest mesh recommended. Use oversize strainers or omit them altogether on applications which require cold starts or use fire resistant fluids.

**OPERATING TEMPERATURES AND VISCOSITIES**

Operating temperatures are a function of fluid viscosities, fluid type, and the pump. Fluid viscosity should be selected to provide the optimum viscosity at normal operating temperatures. For cold starts, the pumps should be operated at low speed and pressure until the fluid warms up to an acceptable viscosity for full power operation.

**WATER CONTAMINATION IN THE FLUID**

Maximum acceptable content of water.  
 • 0.10% for mineral base fluids.  
 • 0.05% for synthetic fluids, crankcase oils, biodegradable fluids.  
 If amount of water is higher then it should be drained off the circuit.

**COUPLINGS AND FEMALE SPLINES SPLINES**

- The mating female spline should be free to float and find its own center. If both members are rigidly supported, they must be aligned within 0,15 TIR or less to reduce fretting. The angular alignment of two spline axes must be less than ± 0,05 per 25,4 radius.
- The coupling spline must be lubricated with a lithium molydisulfide grease or a similar lubricant.
- The coupling must be hardened to a hardness between 27 and 45 R.C.
- The female spline must be made to conform to the Class 1 fit as described in SAE-J498b (1971). This is described as a Flat Root Side Fit.

**RECOMMENDED FLUIDS**

Parker supplies the T6 series keyed shaft pumps with high strength heat-treated keys. Therefore, when installing or replacing these pumps, the heat-treated keys must be used in order to insure maximum life in the application. If the key is replaced, it must be a heat-treated key between 27 and 34 R.C. hardness. The corners of the keys must be chamfered from 0,76 to 1,02 at 45° to clear the radii in the key way.

**NOTE**

The alignment of keyed shafts must be within the tolerances given for splined shafts.

**SHAFT LOADS**

These products are primarily designed for coaxial drives which do not impose axial or side loading on the shaft. Consult specific sections for more details.





**Model No.** T6CR - 022 - 1 L 00 - A 1 0 - A 1 ....

**Series**

**Cam ring**

(Delivery at 0 bar & 1500 r.p.m.)

003 = 16,2 l/min	017 = 87,4 l/min
005 = 25,8 l/min	020 = 95,7 l/min
006 = 31,9 l/min	022 = 105,4 l/min
008 = 39,6 l/min	025 = 118,9 l/min
010 = 51,1 l/min	028 = 133,2 l/min
012 = 55,6 l/min	031 = 150,0 l/min
014 = 69,0 l/min	

**Type of shaft**

1 = keyed (SAE BB)	4 = splined (SAE BB)
2 = keyed (non SAE)	5 = keyed (non SAE)
3 = splined (SAE B)	

**Direct. of rotation (view on shaft end)**

R = clockwise

L = counter-clockwise

**Porting combination**

00 = standard

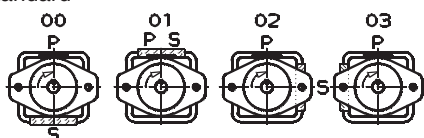

**Modification**

**Seal class**

1 = S1 (for mineral oil)
4 = S4 (for the resistant fluids)
5 = S5 (for mineral oil and fire resistant fluids)

**Design letter**

**Porting adaptor**

**Coupling**

1 = SAE A	4 = SAE C
2 = SAE B	5 = SAE J498b
3 = SAE BB	16/32 - 11 teeth

**Adaptor**

0 = None	B = SAE B
A = SAE A	C = SAE C

*Porting adaptor*

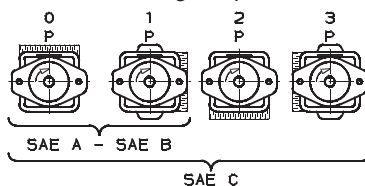

**INTERNAL LEAKAGE (TYPICAL)**

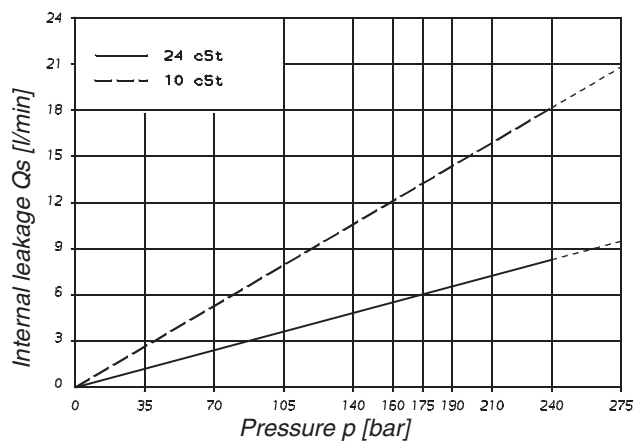

Do not operate the pump more than 5 seconds at any speed or viscosity if internal leakage is more than 50% of theoretical flow

**NOISE LEVEL (TYPICAL)**

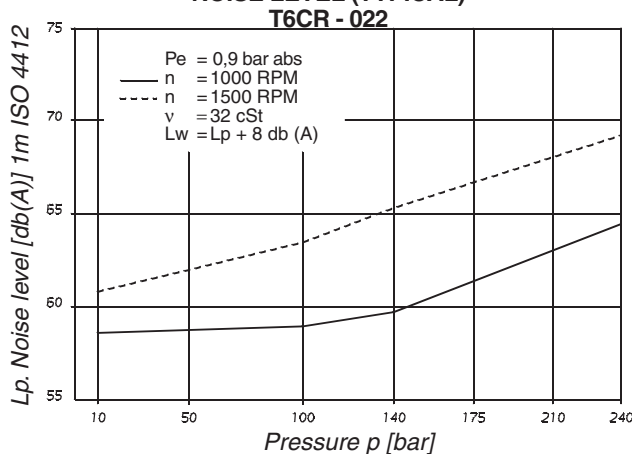

**POWER LOSS HYDROMECHANICAL (TYPICAL)**

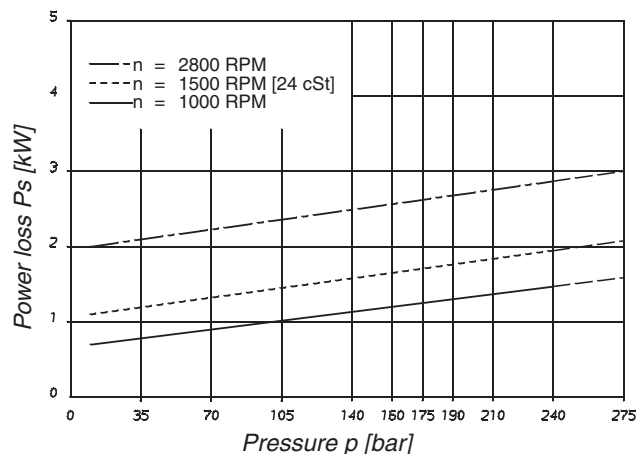

**PERMISSIBLE RADIAL LOAD**

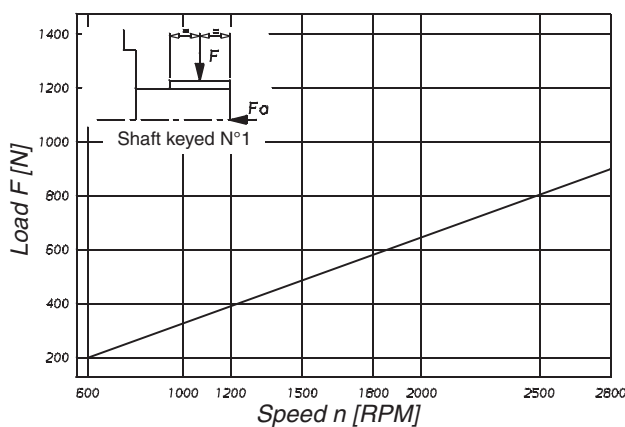

Maximum permissible axial load Fa = 800 N

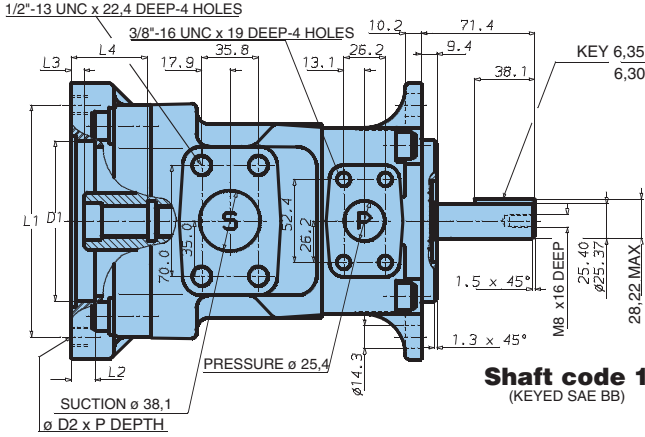
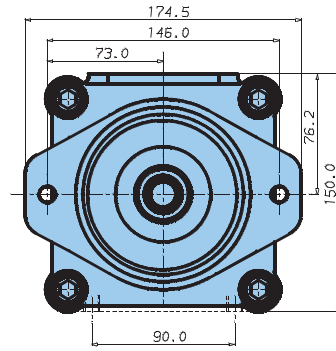
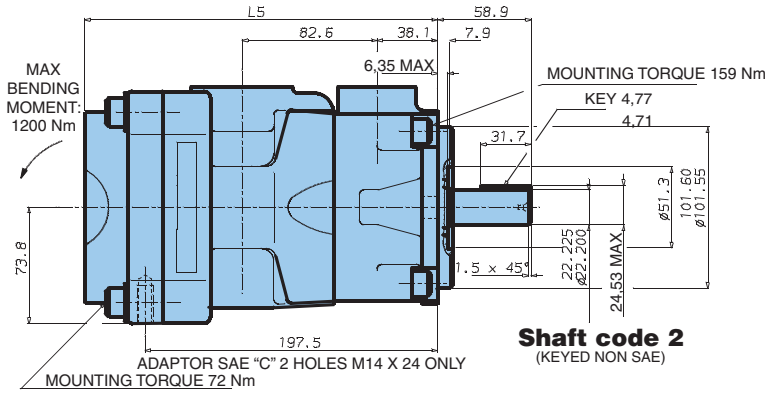

Adaptor	D1	D2	P	L1	L2	L3	L4	L5
SAE A	82,65/82,60	M10	24	106,4	11,0	8,0	32,0	209,0
SAE B	101,70/101,65	M12	28	146,0	16,0	8,0	46,0	223,0
SAE C	127,10/127,05	M16	-	181,0	16,0	8,0	56,0	233,0

Weight 20,4 kg

Adaptor	SAE A			SAE B		SAE C
Coupling drive	SAE A	SAE 11 teeth	SAE B	SAE B	SAE BB	SAE C
Number of teeth	9	11	13	13	15	14
Pitch	16/32	16/32	16/32	16/32	16/32	12/24
Pressure angle	30°	30°	30°	30°	30°	30°
Major dia. (min)	15,875	19,05	22,225	22,225	25,400	31,750
Minor dia. (min)	12,700	16,017	19,134	19,134	22,268	27,589

Shaft torque limits [ml/rev x bar]			
Shaft	Vi x p max.	Coupling drive	Vi x p max.
1	21420	SAE A	11000
2	14300	SAE B	20600
3	20600	SAE BB	22050
4	32670	SAE C	22050
5	34180	SAE - 11 teeth	15850

**OPERATING CHARACTERISTICS - TYPICAL [24 cSt]**

Series	Volumetric Displacement Vi	Flow Q [l/min] & n = 1500 RPM			Input power P [kW] & n = 1500 RPM		
		p = 0 bar	p = 140 bar	p = 240 bar	p = 7 bar	p = 140 bar	p = 240 bar
003	10,8 ml/rev	16,2	11,2	7,7	1,3	5,3	8,4
005	17,2 ml/rev	25,8	20,8	17,3	1,4	7,5	12,2
006	21,3 ml/rev	31,9	26,9	23,4	1,5	8,9	14,7
008	26,4 ml/rev	39,6	34,6	31,1	1,6	10,7	17,7
010	34,1 ml/rev	51,1	46,1	42,6	1,7	13,4	22,3
012	37,1 ml/rev	55,6	50,6	47,1	1,7	14,4	24,1
014	46,0 ml/rev	69,0	64,0	60,5	1,9	17,6	29,5
017	58,3 ml/rev	87,4	82,4	78,9	2,1	21,9	36,9
020	63,8 ml/rev	95,7	90,7	87,2	2,2	23,8	40,2
022	70,3 ml/rev	105,4	100,4	96,9	2,3	26,1	44,1
025 <sup>1)</sup>	79,3 ml/rev	118,9	113,9	110,4	2,5	29,2	49,5
028 <sup>1)</sup>	88,8 ml/rev	133,2	128,2	125,8 <sup>2)</sup>	2,8	32,7	48,5 <sup>2)</sup>
031 <sup>1)</sup>	100,0 ml/rev	150,0	145,0	142,6 <sup>2)</sup>	2,8	36,5	54,4 <sup>2)</sup>

<sup>1)</sup> 025 - 028 - 031 = 2500 R.P.M. max.

<sup>2)</sup> 028 - 031 = 210 bar max. int.

Port connection can be furnished with metric threads.

**Model No.** T6DR - 022 - 1 L 00 - A 1 0 - A 1 ....

**Series**

**Cam ring**

(Delivery at 0 bar & 1500 r.p.m.)

014 = 71,4 l/min	035 = 166,5 l/min
017 = 87,3 l/min	038 = 180,4 l/min
020 = 99,0 l/min	042 = 204,0 l/min
024 = 119,3 l/min	045 = 218,5 l/min
028 = 134,5 l/min	050 = 237,0 l/min
031 = 147,4 l/min	

**Type of shaft**

- 1 = keyed (SAE C)
- 2 = keyed (SAE CC)
- 3 = splined (SAE C)
- 5 = keyed (non SAE)

**Direct. of rotation (view on shaft end)**

- R = clockwise
- L = counter-clockwise

**Porting combination**

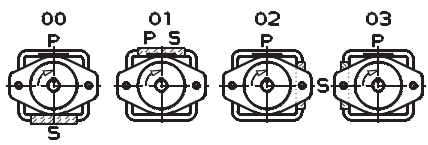

**Modification**

**Seal class**

- 1 = S1 (for mineral oil)
- 4 = S4 (for the resistant fluids)
- 5 = S5 (for mineral oil and fire resistant fluids)

**Design letter**

**Porting adaptor**

**Coupling**

- 1 = SAE A
- 2 = SAE B
- 3 = SAE BB
- 4 = SAE C
- 5 = SAE J498b
- 16/32 - 11 teeth

**Adaptor**

- 0 = None
- A = SAE A
- B = SAE B
- C = SAE C

**Porting adaptor**

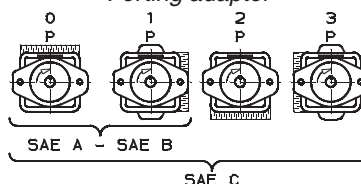

**INTERNAL LEAKAGE (TYPICAL)**

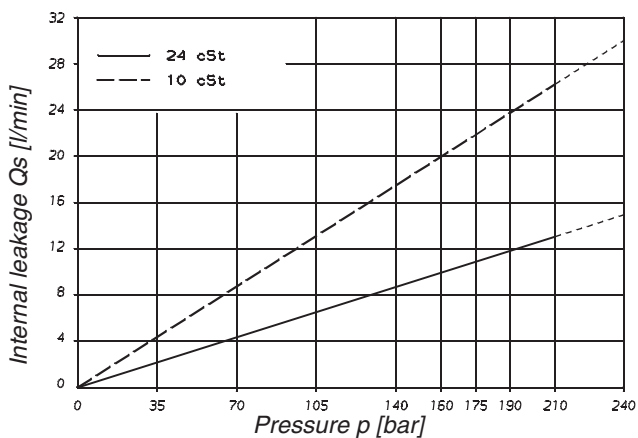

Do not operate the pump more than 5 seconds at any speed or viscosity if internal leakage is more than 50% of theoretical flow

**NOISE LEVEL (TYPICAL)**

T6DR - 038

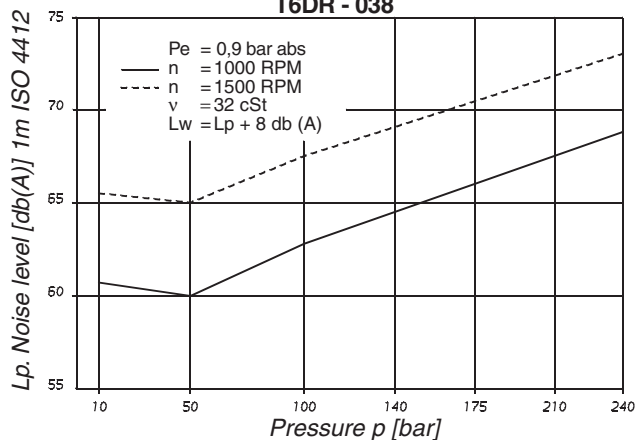

**POWER LOSS HYDROMECHANICAL (TYPICAL)**

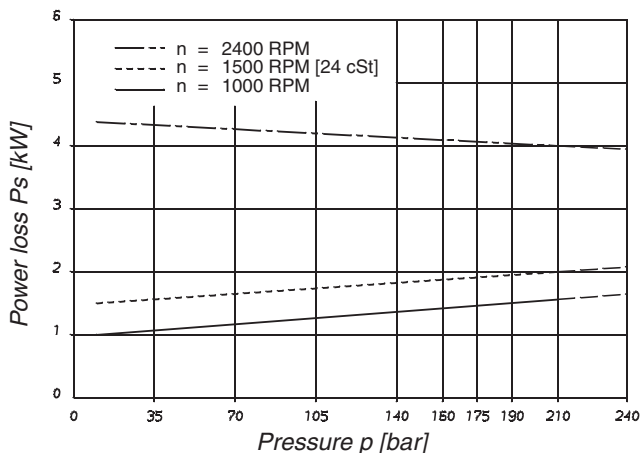

**PERMISSIBLE RADIAL LOAD**

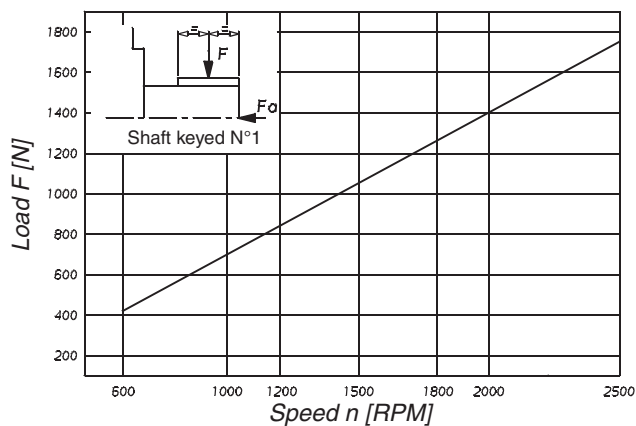

Maximum permissible axial load Fa = 1200 N

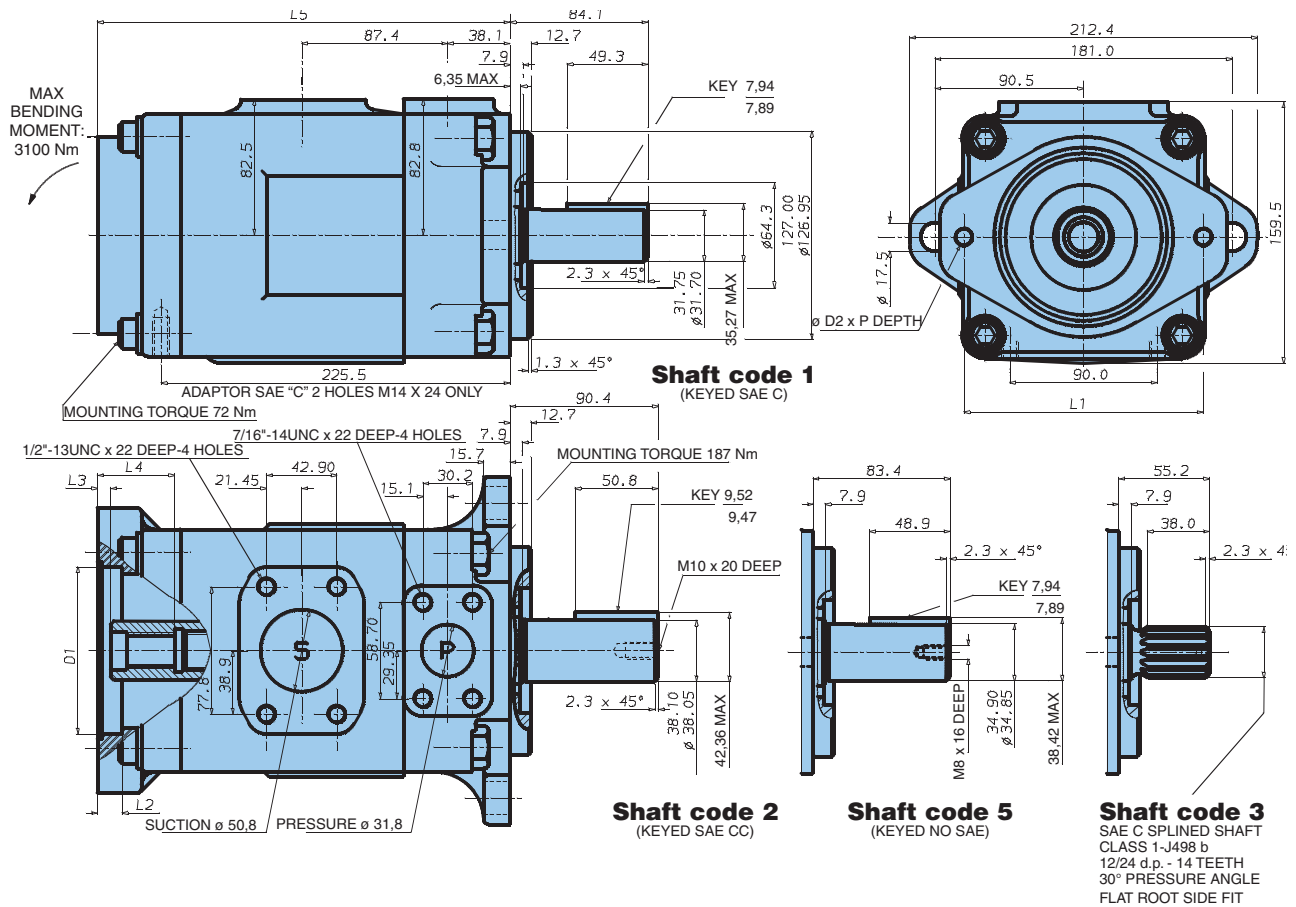

Adaptor	D1	D2	P	L1	L2	L3	L4	L5
SAE A	82,65/82,60	M10	24	106,4	11,0	8,0	32,0	237,0
SAE B	101,70/101,65	M12	28	146,0	16,0	8,0	46,0	251,0
SAE C	127,10/127,05	M16	-	181,0	16,0	8,0	56,0	261,0

Weight 32,3 kg

Adaptor	SAE A		SAE B		SAE C
Coupling drive	SAE A	SAE 11 teeth	SAE B	SAE BB	SAE C
Number of teeth	9	11	13	15	14
Pitch	16/32	16/32	16/32	16/32	12/24
Pressure angle	30°	30°	30°	30°	30°
Major dia. (min)	15,875	19,05	22,225	25,400	31,750
Minor dia. (min)	12,700	16,017	19,134	22,268	27,589

Shaft torque limits [ml/rev x bar]			
Shaft	Vi x p max.	Coupling drive	Vi x p max.
1	43240	SAE A	11000
2	66036	SAE B	20600
3	61200	SAE BB	32670
5	55600	SAE C	37390
		SAE - 11 teeth	15850

**OPERATING CHARACTERISTICS - TYPICAL [24 cSt]**

Series	Volumetric Displacement Vi	Flow Q [l/min] & n = 1500 RPM			Input power P [kW] & n = 1500 RPM		
		p = 0 bar	p = 140 bar	p = 240 bar	p = 7 bar	p = 140 bar	p = 240 bar
014	47,6 ml/rev	71,4	62,1	55,9	2,3	18,5	30,6
017	58,2 ml/rev	87,3	78,0	71,8	2,5	22,2	37,0
020	66,0 ml/rev	99,0	89,7	83,5	2,8	24,9	41,7
024	79,5 ml/rev	119,3	110,0	103,8	3,0	29,6	49,8
028	89,7 ml/rev	134,5	125,2	119,0	3,2	33,2	55,9
031	98,3 ml/rev	147,4	138,1	131,9	3,3	36,2	61,1
035	111,0 ml/rev	166,5	157,2	151,0	3,5	40,7	68,7
038	120,3 ml/rev	180,4	171,1	164,9	3,7	43,9	74,3
042 <sup>1)</sup>	136,0 ml/rev	204,0	194,7	188,5	4,0	49,4	83,7
045 <sup>1)</sup>	145,7 ml/rev	218,5	209,2	203,0	4,1	52,8	89,5
050 <sup>1)</sup>	158,0 ml/rev	237,0	227,7	224,0 <sup>2)</sup>	4,4	57,0	85,0 <sup>2)</sup>

<sup>1)</sup> 042 - 045 - 050 = 2200 R.P.M. max.

<sup>2)</sup> 050 = 210 bar max. int.

Port connection can be furnished with metric threads.

Model No. **T6ER - 066 - 1 R 00 - A 1 0 - A 1 ..**

**Series**

**Cam ring**

(Delivery at 0 bar & 1500 r.p.m.)

042 = 198,5 l/min      062 = 295,0 l/min

045 = 213,6 l/min      066 = 319,9 l/min

050 = 237,7 l/min      072 = 340,6 l/min

052 = 247,2 l/min

**Type of shaft**

1 = keyed (SAE CC)

3 = splined (SAE C)

4 = splined (SAE CC)

**Direct. of rotation (view on shaft end)**

R = clockwise

L = counter-clockwise

**Porting combination**

**Modification**

**Seal class**

1 = S1 (for mineral oil)

4 = S4 (for the resistant fluids)

5 = S5 (for mineral oil and fire resistant fluids)

**Design letter**

**Porting adaptor**

**Coupling**

1 = SAE A

2 = SAE B

3 = SAE BB

4 = SAE C

5 = SAE J498b

16/32 - 11 teeth

**Adaptor**

0 = None

A = SAE A

B = SAE B

C = SAE C

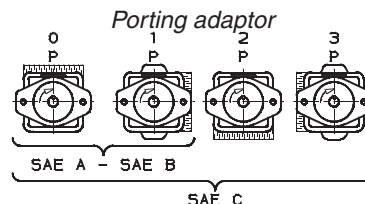
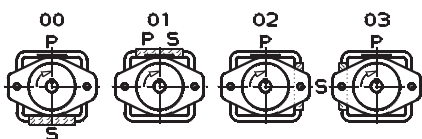

**INTERNAL LEAKAGE (TYPICAL)**

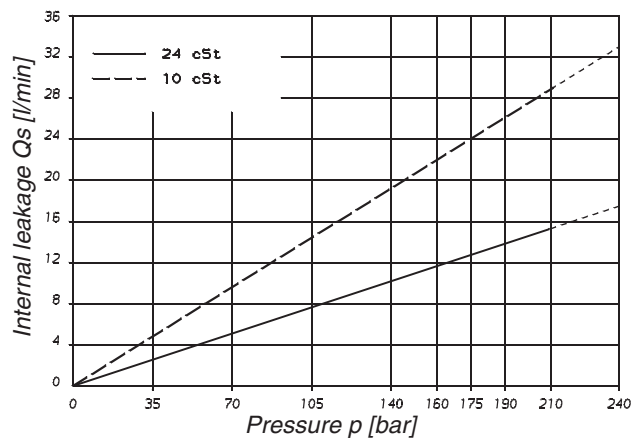

**NOISE LEVEL (TYPICAL)  
T6ER - 050**

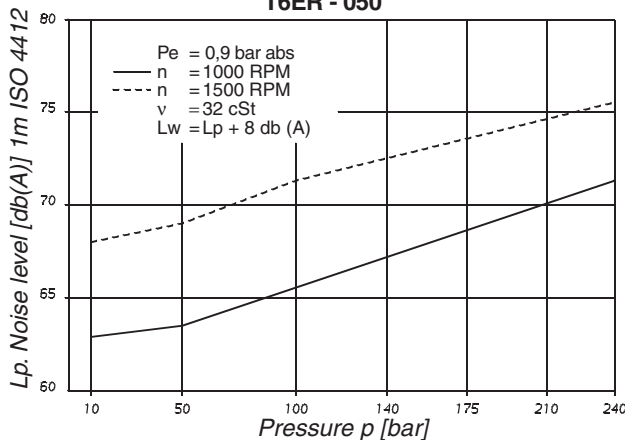

**POWER LOSS HYDROMECHANICAL (TYPICAL)**

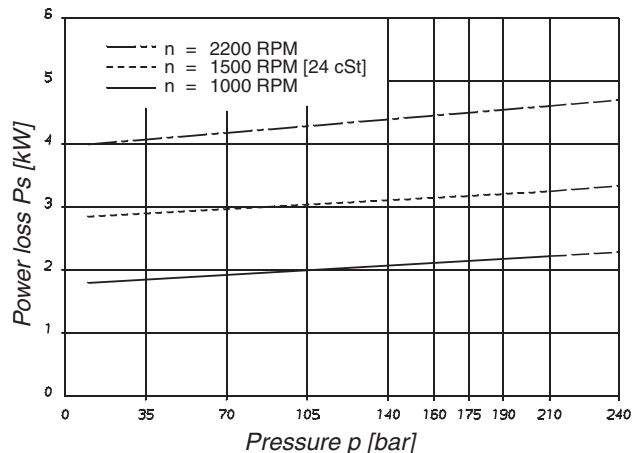

**PERMISSIBLE RADIAL LOAD**

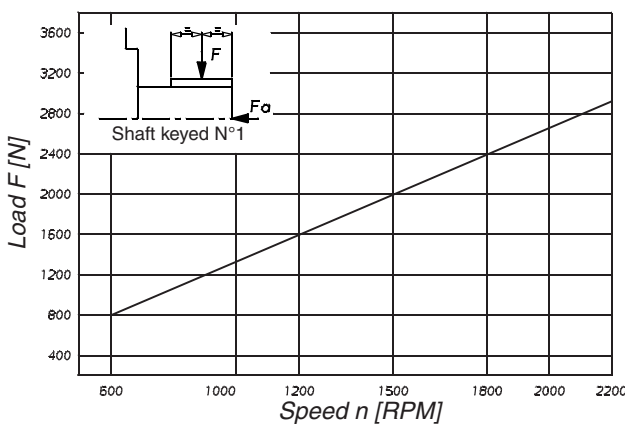

Maximum permissible axial load Fa = 2000 N

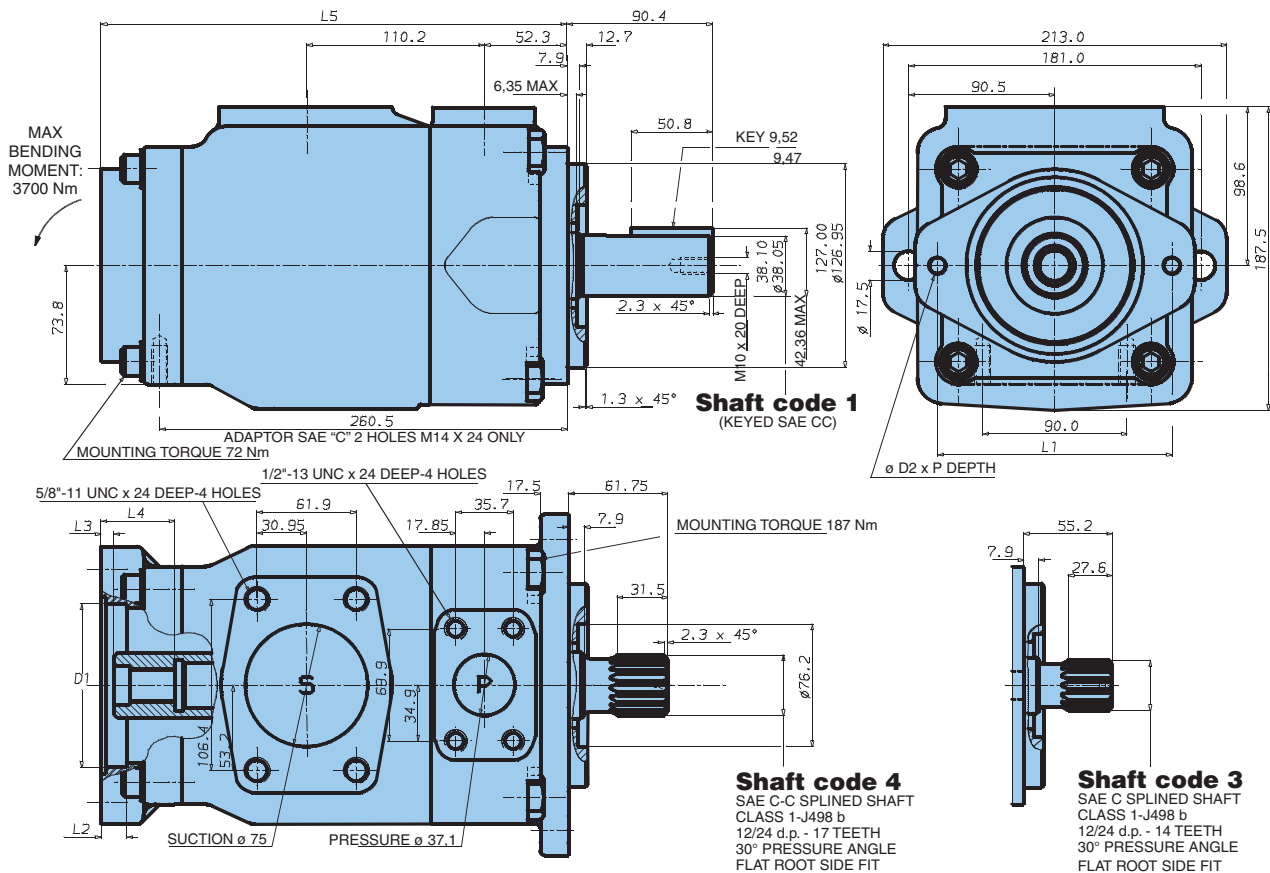

Weight 42.5 kg

Adaptor	D1	D2	P	L1	L2	L3	L4	L5
SAE A	82,65/82,60	M10	24	106,4	11,0	8,0	32,0	272,0
SAE B	101,70/101,65	M12	28	146,0	16,0	8,0	46,0	286,0
SAE C	127,10/127,05	M16	-	181,0	16,0	8,0	56,0	296,0

Adaptor	SAE A			SAE B		SAE C
Coupling drive	SAE A	SAE 11 teeth	SAE B	SAE B	SAE BB	SAE C
Number of teeth	9	11	13	13	15	14
Pitch	16/32	16/32	16/32	16/32	16/32	12/24
Pressure angle	30°	30°	30°	30°	30°	30°
Major dia. (min)	15,875	19,05	22,225	22,225	25,400	31,750
Minor dia. (min)	12,700	16,017	19,134	19,134	22,268	27,589

Shaft torque limits [ml/rev x bar]			
Shaft	Vi x p max.	Coupling drive	Vi x p max.
1	80560	SAE A	11000
2	61200	SAE B	20600
4	120210	SAE BB	32670
		SAE C	66480
		SAE - 11 teeth	15850

**OPERATING CHARACTERISTICS - TYPICAL [24 cSt]**

Series	Volumetric Displacement Vi	Flow Q [l/min] & n = 1500 RPM			Input power P [kW] & n = 1500 RPM		
		p = 0 bar	p = 140 bar	p = 240 bar	p = 7 bar	p = 140 bar	p = 240 bar
042	132,3 ml/rev	198,5	188,5	181,3	5,2	49,4	82,6
045	142,4 ml/rev	213,6	203,6	196,5	5,4	52,9	88,7
050	158,5 ml/rev	237,7	227,7	220,6	5,7	58,5	98,3
052	164,8 ml/rev	247,2	237,2	230,1	5,8	60,8	102,1
062	196,7 ml/rev	295,0	285,0	277,7	6,4	71,9	121,3
066	213,3 ml/rev	319,9	309,9	302,8	6,7	77,7	131,2
072	227,1 ml/rev	340,6	330,6	323,5	6,9	82,6	139,5

Port connection can be furnished with metric threads.

Model No. T6DCCR - 038 - 028 - 008 - 2 R 00 - A 1 - 00 ..

Series

Rear cap end for mounting  
SAE A auxiliary pump  
coupling adaptor  
SAE A - 9 teeth

Cam ring for "P1"

(Delivery at 0 bar & 1500 r.p.m.)

014 = 71,4 l/min	035 = 166,5 l/min
017 = 87,3 l/min	038 = 180,4 l/min
020 = 99,0 l/min	042 = 204,0 l/min
024 = 119,3 l/min	045 = 218,5 l/min
028 = 134,5 l/min	050 = 237,0 l/min
031 = 147,4 l/min	

Cam ring for "P2" & "P3"

(Delivery at 0 bar & 1500 r.p.m.)

003 = 16,2 l/min	017 = 87,4 l/min
005 = 25,8 l/min	020 = 95,7 l/min
006 = 31,9 l/min	022 = 105,4 l/min
008 = 39,6 l/min	025 = 118,9 l/min
010 = 51,1 l/min	028 = 133,2 l/min
012 = 55,6 l/min	031 = 150,0 l/min
014 = 69,0 l/min	

Modification

Mounting W/connection variables  
4 bolts SAE flange (J518c)

Type	UNC		Metric	
	1"	3/4"	1"	3/4"
P3	1"	3/4"	1"	3/4"
Code	00	01	M0	M1

Seal class

1 = S1 (for mineral oil)  
4 = S4 (for the resistant fluids)  
5 = S5 (for mineral oil and fire resistant fluids)

Design letter

Porting combination (see pages 22 - 23)

00 = standard

Direct. of rotation (view on shaft end)

R = clockwise  
L = counter-clockwise

Type of shaft

2 = keyed (SAE CC)  
3 = splined (SAE D & E)

**OPERATING CHARACTERISTICS - TYPICAL [24 cSt]**

Pressure Port	Series	Volumetric Displacement Vi	Flow Q [l/min] & n = 1500 RPM			Input power P [kW] & n = 1500 RPM		
			p = 0 bar	p = 140 bar	p = 240 bar	p = 7 bar	p = 140 bar	p = 240 bar
P1	014	47,6 ml/rev	71,4	62,1	55,9	2,3	18,5	30,6
	017	58,2 ml/rev	87,3	78,0	71,8	2,5	22,2	37,0
	020	66,0 ml/rev	99,0	89,7	83,5	2,8	24,9	41,7
	024	79,5 ml/rev	119,3	110,0	103,8	3,0	29,6	49,8
	028	89,7 ml/rev	134,5	125,2	119,0	3,2	33,2	55,9
	031	98,3 ml/rev	147,4	138,1	131,9	3,3	36,2	61,0
	035	111,0 ml/rev	166,5	157,2	151,0	3,5	40,7	68,7
	038	120,3 ml/rev	180,4	171,1	164,9	3,7	43,9	74,3
	042 <sup>2)</sup>	136,0 ml/rev	204,0	194,7	188,5	4,0	49,4	83,9
	045 <sup>2)</sup>	145,7 ml/rev	218,5	209,2	203,0	4,1	52,8	89,5
	050 <sup>2)</sup>	158,0 ml/rev	237,0	227,7	224,0 <sup>1)</sup>	4,4	57,0	85,0 <sup>1)</sup>
P2 & P3	003	10,8 ml/rev	16,2	11,2	7,7	1,3	5,3	8,4
	005	17,2 ml/rev	25,8	20,8	17,3	1,4	7,5	12,2
	006	21,3 ml/rev	31,9	26,9	23,4	1,5	8,9	14,7
	008	26,4 ml/rev	39,6	34,6	31,1	1,6	10,7	17,7
	010	34,1 ml/rev	51,1	46,1	42,6	1,7	13,4	22,3
	012	37,1 ml/rev	55,6	50,6	47,1	1,7	14,4	24,1
	014	46,0 ml/rev	69,0	64,0	60,5	1,9	17,6	29,5
	017	58,3 ml/rev	87,4	82,4	78,9	2,1	21,9	36,9
	020	63,8 ml/rev	95,7	90,7	87,2	2,2	23,8	40,2
	022	70,3 ml/rev	105,4	100,4	96,9	2,3	26,1	44,1
	025	79,3 ml/rev	118,9	113,9	110,4	2,5	29,2	49,5
	028	88,8 ml/rev	133,2	128,2	125,8 <sup>1)</sup>	2,8	32,7	48,5 <sup>1)</sup>
	031	100,0 ml/rev	150,0	145,0	142,6 <sup>1)</sup>	2,8	36,5	54,4 <sup>1)</sup>

<sup>1)</sup> 028 - 031 - 050 = 210 bar max. int.

<sup>2)</sup> 042 - 045 - 050 = 2200 R.P.M max.



**INTERNAL LEAKAGE (TYPICAL)**

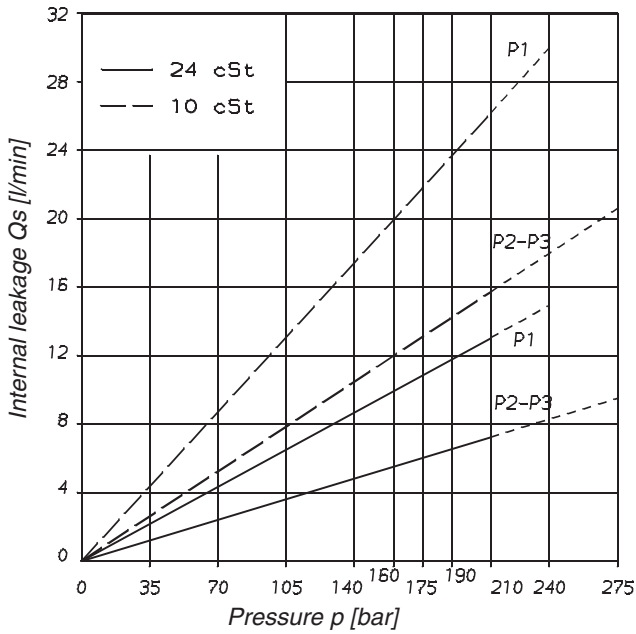

Total leakage is the sum of each section loss at its operating conditions.

**NOISE LEVEL (TYPICAL)**  
 T6DCCR - 038 - 022 - 022

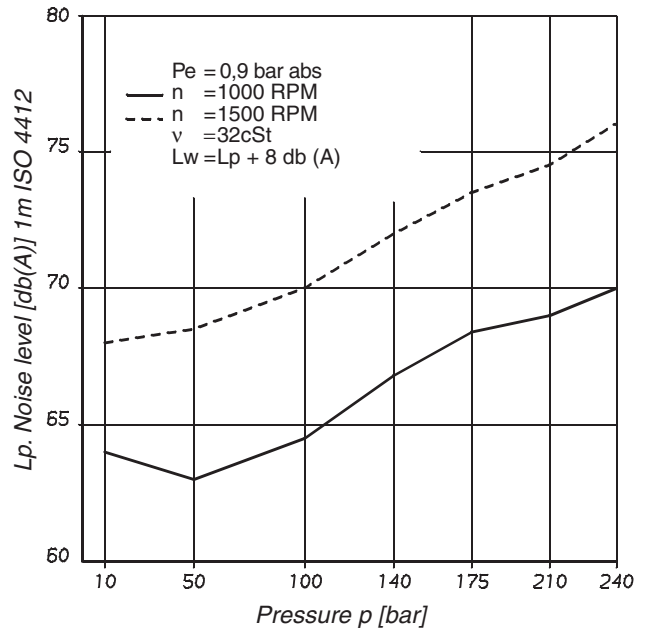

Triple pump noise level is given with each section discharging at the pressure noted on the curve.

**HYDROMECHANICAL POWER LOSS (TYPICAL)**

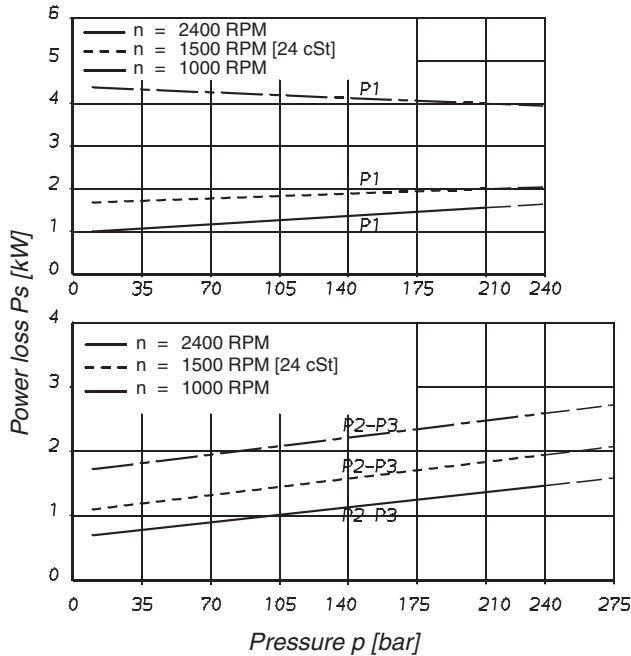

Total hydrodynamic power loss is the sum of each section at its operating conditions.

**PERMISSIBLE RADIAL LOAD**

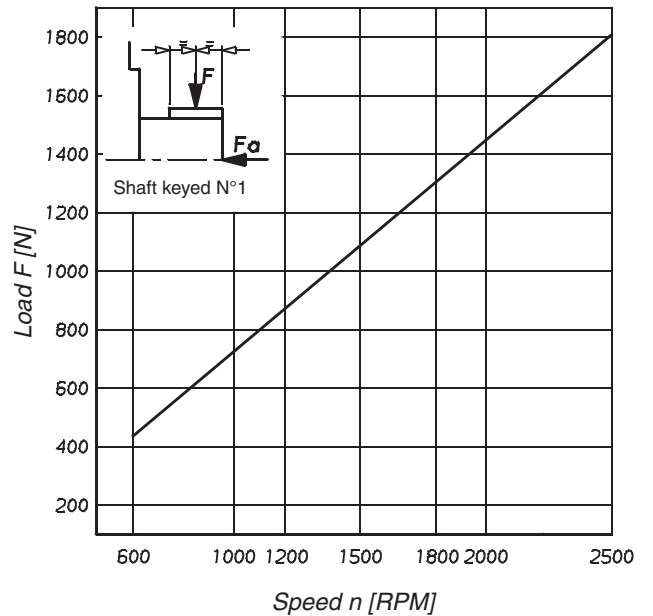

Maximum permissible axial load  $F_a = 1200$  N

Weight 62,0 kg

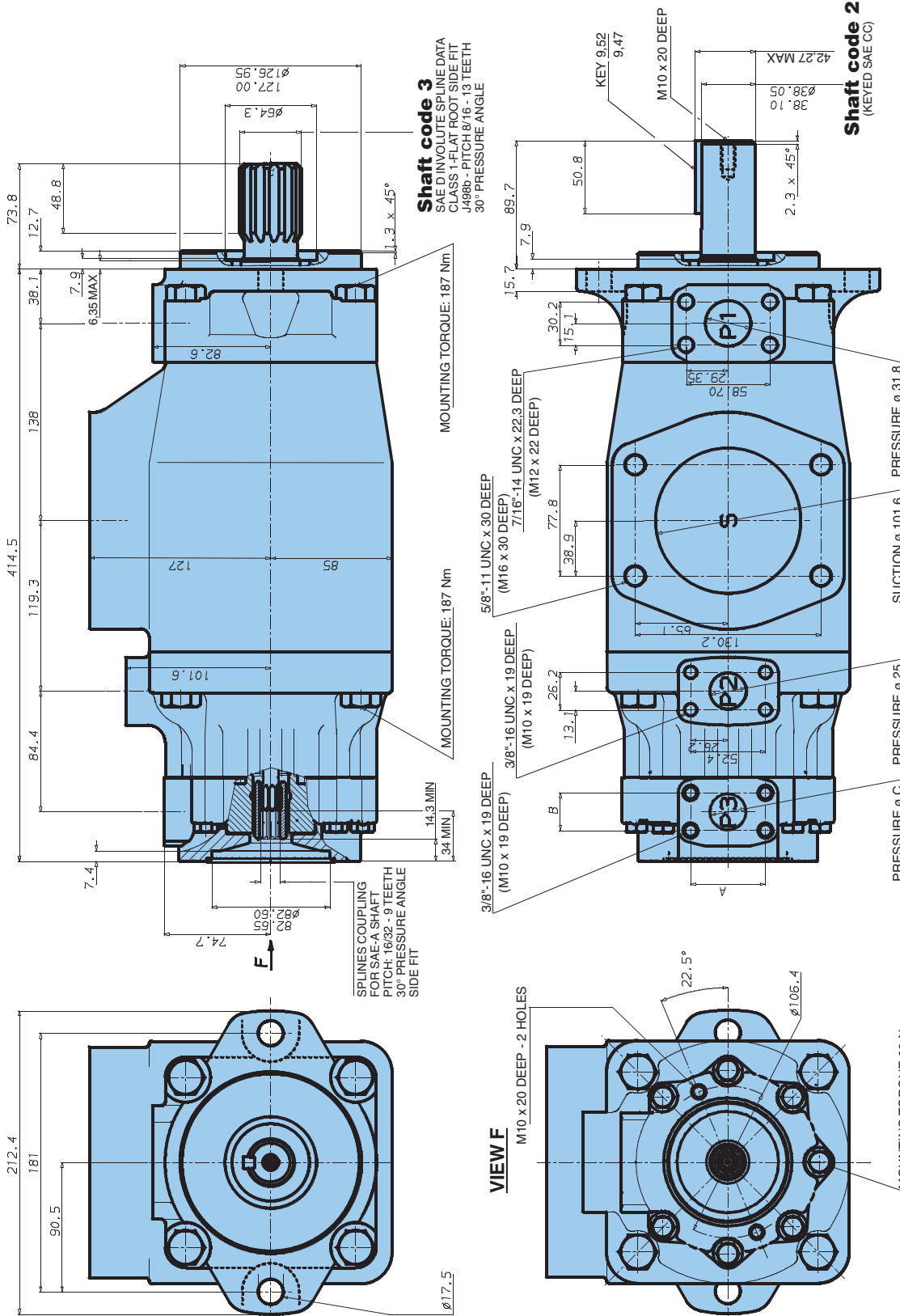

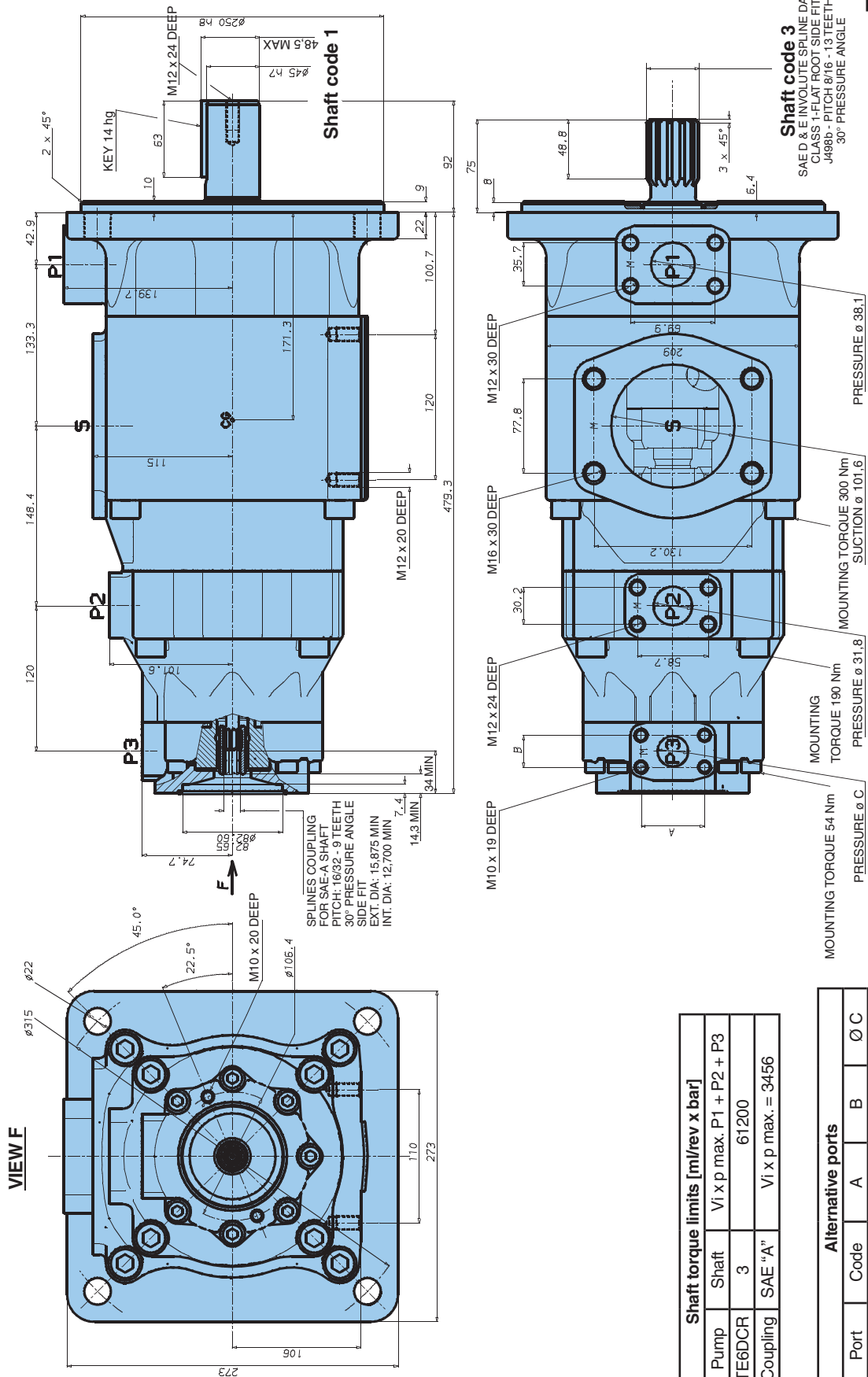

Model No. T6EDCR - 062 - 035 - 017 - 1 R 00 - A P 1- 00 ..

**Series**

Rear cap end for mounting

SAE A auxiliary pump

coupling adaptor

SAE A - 9 teeth

Cam ring for "P1"

(Delivery at 0 bar & 1500 r.p.m.)

042 = 198,5 l/min 062 = 295,0 l/min

045 = 213,6 l/min 066 = 319,9 l/min

050 = 237,7 l/min 072 = 340,6 l/min

052 = 247,2 l/min

Cam ring for "P2"

(Delivery at 0 bar & 1500 r.p.m.)

014 = 71,4 l/min 035 = 166,5 l/min

017 = 87,3 l/min 038 = 180,4 l/min

020 = 99,0 l/min 042 = 204,0 l/min

024 = 119,3 l/min 045 = 218,5 l/min

028 = 134,5 l/min 050 = 237,0 l/min

031 = 147,4 l/min

Cam ring for "P3"

(Delivery at 0 bar & 1500 r.p.m.)

003 = 16,2 l/min 012 = 55,6 l/min 022 = 105,4 l/min

005 = 25,8 l/min 014 = 69,0 l/min 025 = 118,9 l/min

006 = 31,9 l/min 017 = 87,4 l/min 028 = 133,2 l/min

008 = 39,6 l/min 020 = 95,7 l/min 031 = 150,0 l/min

010 = 51,1 l/min

**Modification**

Mounting W/connection variables

0 = P3 = 1" SAE

1 = P3 = 3/4" SAE

**Options**

P = 4 holes for external support

**Seal class**

1 = S1 (for mineral oil)

4 = S4 (for the resistant fluids)

5 = S5 (for mineral oil and fire resistant fluids)

**Design letter**

Porting combination (see pages 22 - 23)

00 = standard

Direct. of rotation (view on shaft end)

R = clockwise

L = counter-clockwise

**Type of shaft**

1 = keyed (G45N - ISO 3019-2)

3 = splined (SAE D & E)

**OPERATING CHARACTERISTICS - TYPICAL [24 cSt]**

Pressure Port	Series	Volumetric Displacement Vi	Flow Q [l/min] & n = 1500 RPM			Input power P [kW] & n = 1500 RPM		
			p = 0 bar	p = 140 bar	p = 240 bar	p = 7 bar	p = 140 bar	p = 240 bar
P1	042	132,3 ml/rev	198,5	188,5	181,3	5,2	49,4	82,6
	045	142,4 ml/rev	213,6	203,6	196,5	5,4	52,9	88,7
	050	158,5 ml/rev	237,7	227,7	220,6	5,7	58,5	98,3
	052	164,8 ml/rev	247,2	237,2	230,1	5,8	60,8	102,1
	062	196,7 ml/rev	295,0	285,0	277,9	6,4	71,9	121,3
	066	213,3 ml/rev	319,9	309,9	302,8	6,7	77,7	131,2
	072	227,1 ml/rev	340,6	330,6	323,5	6,9	82,6	139,5
P2	014	47,6 ml/rev	71,4	62,1	55,9	2,3	18,5	30,6
	017	58,2 ml/rev	87,3	78,0	71,8	2,5	22,2	37,0
	020	66,0 ml/rev	99,0	89,7	83,5	2,8	24,9	41,7
	024	79,5 ml/rev	119,3	110,0	103,8	3,0	29,6	49,8
	028	89,7 ml/rev	134,5	125,2	119,0	3,2	33,2	55,9
	031	98,3 ml/rev	147,4	138,1	131,9	3,3	36,2	61,0
	035	111,0 ml/rev	166,5	157,2	151,0	3,5	40,7	68,7
	038	120,3 ml/rev	180,4	171,1	164,9	3,7	43,9	74,3
	042 <sup>2)</sup>	136,0 ml/rev	204,0	194,7	188,5	4,0	49,4	83,7
	045 <sup>2)</sup>	145,7 ml/rev	218,5	209,2	203,0	4,1	52,8	89,5
050 <sup>2)</sup>	158,0 ml/rev	237,0	227,7	224,0 <sup>1)</sup>	4,4	57,0	85,0 <sup>1)</sup>	
P3	003	10,8 ml/rev	16,2	11,2	7,7	1,3	5,3	8,4
	005	17,2 ml/rev	25,8	20,8	17,3	1,4	7,5	12,2
	006	21,3 ml/rev	31,9	26,9	23,4	1,5	8,9	14,7
	008	26,4 ml/rev	39,6	34,6	31,1	1,6	10,7	17,7
	010	34,1 ml/rev	51,1	46,1	42,6	1,7	13,4	22,3
	012	37,1 ml/rev	55,6	50,6	47,1	1,7	14,4	24,1
	014	46,0 ml/rev	69,0	64,0	60,5	1,9	17,6	29,5
	017	58,3 ml/rev	87,4	82,4	78,9	2,1	21,9	36,9
	020	63,8 ml/rev	95,7	90,7	87,2	2,2	23,8	40,2
	022	70,3 ml/rev	105,4	100,4	96,9	2,3	26,1	44,1
	025	79,3 ml/rev	118,9	113,9	110,4	2,5	29,2	49,5
	028	88,8 ml/rev	133,2	128,2	125,8 <sup>1)</sup>	2,8	32,7	48,5 <sup>1)</sup>
	031	100,0 ml/rev	150,0	145,0	142,6 <sup>1)</sup>	2,8	36,5	54,4 <sup>1)</sup>

<sup>1)</sup> 028 - 031 - 050 = 210 bar max. int.

<sup>2)</sup> 042 - 045 - 050 = 2200 R.P.M max.

**INTERNAL LEAKAGE (TYPICAL)**

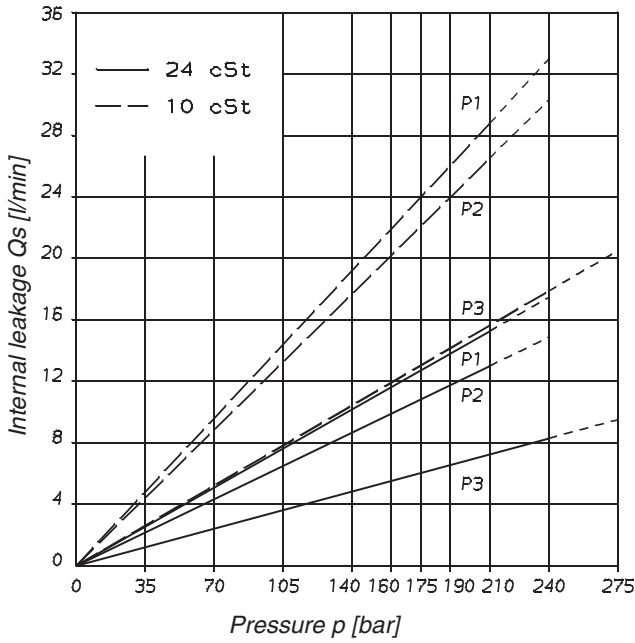

Total leakage is the sum of each section loss at its operating conditions.

**NOISE LEVEL (TYPICAL)**  
**T6EDCR - 062 - 035 - 017**

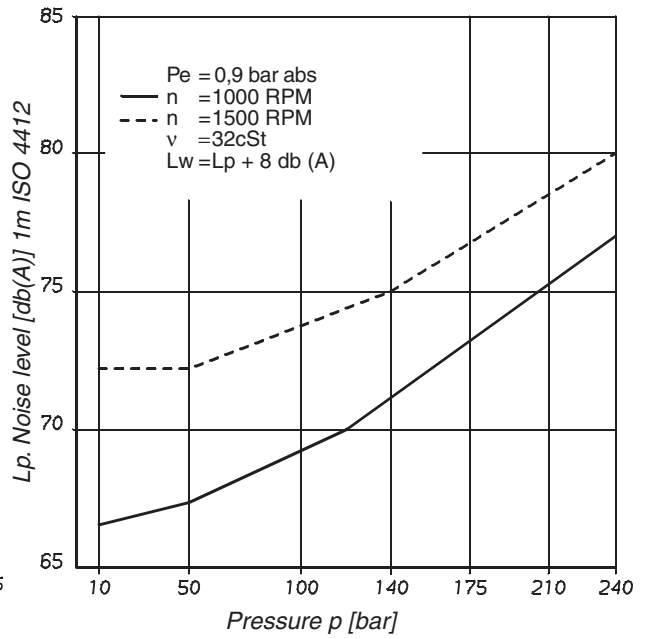

Triple pump noise level is given with each section discharging at the pressure noted on the curve.

**HYDROMECHANICAL POWER LOSS (TYPICAL)**

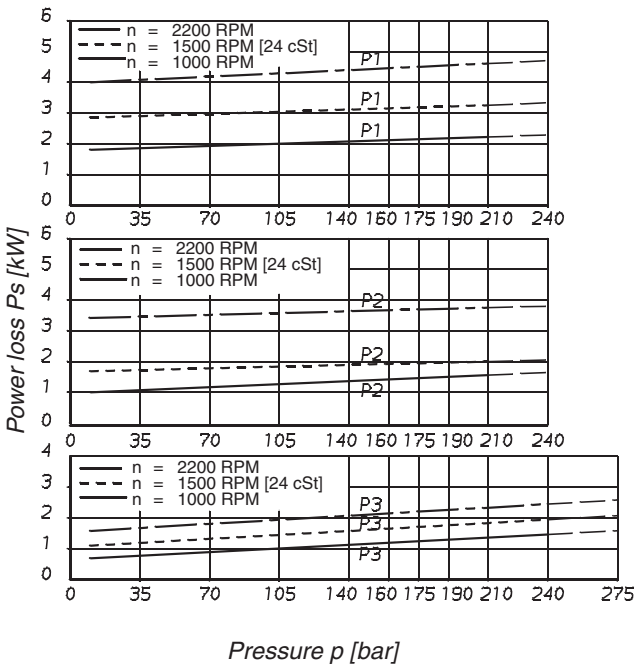

Total hydrodynamic power loss is the sum of each section at its operating conditions.

**PERMISSIBLE RADIAL LOAD**

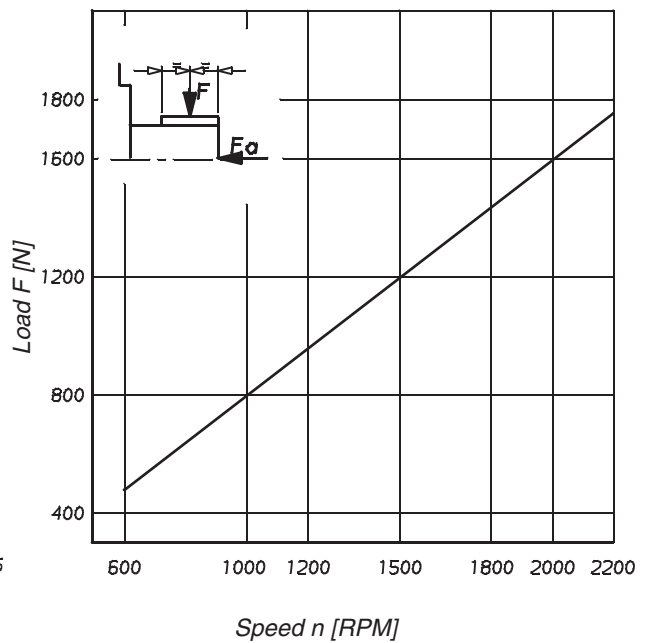

Maximum permissible axial load  $F_a = 2000$  N

**Industrial application**

**T6DCCR - T6EDCR**  
 (View from shaft end)

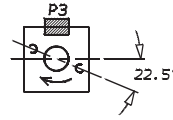

<b>00</b> P1-P2-P3 	<b>01</b> P1-P2-P3 	<b>02</b> S-P1-P2-P3 	<b>03</b> P1-P2-P3 	<b>04</b> P1 	<b>05</b> P1 	<b>06</b> P1 	<b>07</b> P1-S 
<b>08</b> P1-S 	<b>09</b> P1-S 	<b>10</b> P1 	<b>11</b> P1-P2 	<b>12</b> P1-P2 	<b>13</b> P1-P3 	<b>14</b> P1 	<b>15</b> P1-P3 
<b>16</b> S-P1-P2 	<b>17</b> S-P1-P2 	<b>18</b> S-P1-P2 	<b>19</b> S-P1-P3 	<b>20</b> S-P1-P3 	<b>21</b> S-P1-P3 	<b>22</b> P1-P2 	<b>23</b> P1 
<b>24</b> P1 	<b>25</b> P1 	<b>26</b> P1 	<b>27</b> P1-P3 	<b>28</b> P1-S 	<b>29</b> P1-S 	<b>30</b> P1-S 	<b>31</b> P1-S 
<b>32</b> P1-S 	<b>33</b> P1-S 	<b>34</b> P1-P2 	<b>35</b> P1-P2 	<b>36</b> P1-P2 	<b>37</b> P1-P2 	<b>38</b> P1-P2 	<b>39</b> P1-P2 
<b>40</b> P1-P3 	<b>41</b> P1-P3 	<b>42</b> P1-P3 	<b>43</b> P1-P3 	<b>44</b> P1-P3 	<b>45</b> P1-P3 	<b>46</b> P1 	<b>47</b> P1 
<b>48</b> P1 	<b>49</b> P1 	<b>50</b> P1 	<b>51</b> P1 	<b>52</b> P1 	<b>53</b> P1 	<b>54</b> P1 	<b>55</b> P1 
<b>56</b> P1 	<b>57</b> P1 	<b>58</b> P1 	<b>59</b> P1 	<b>60</b> P1 	<b>61</b> P1 	<b>62</b> P1 	<b>63</b> P1 

**Industrial application**

**T6DCCR - T6EDCR**  
 (View from shaft end)

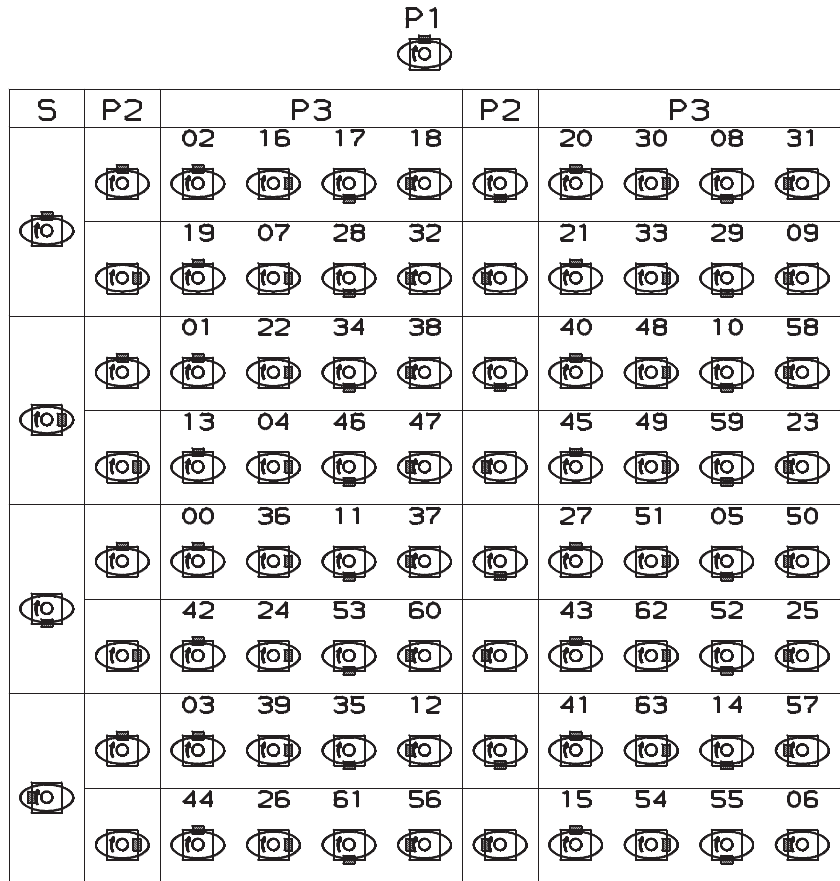

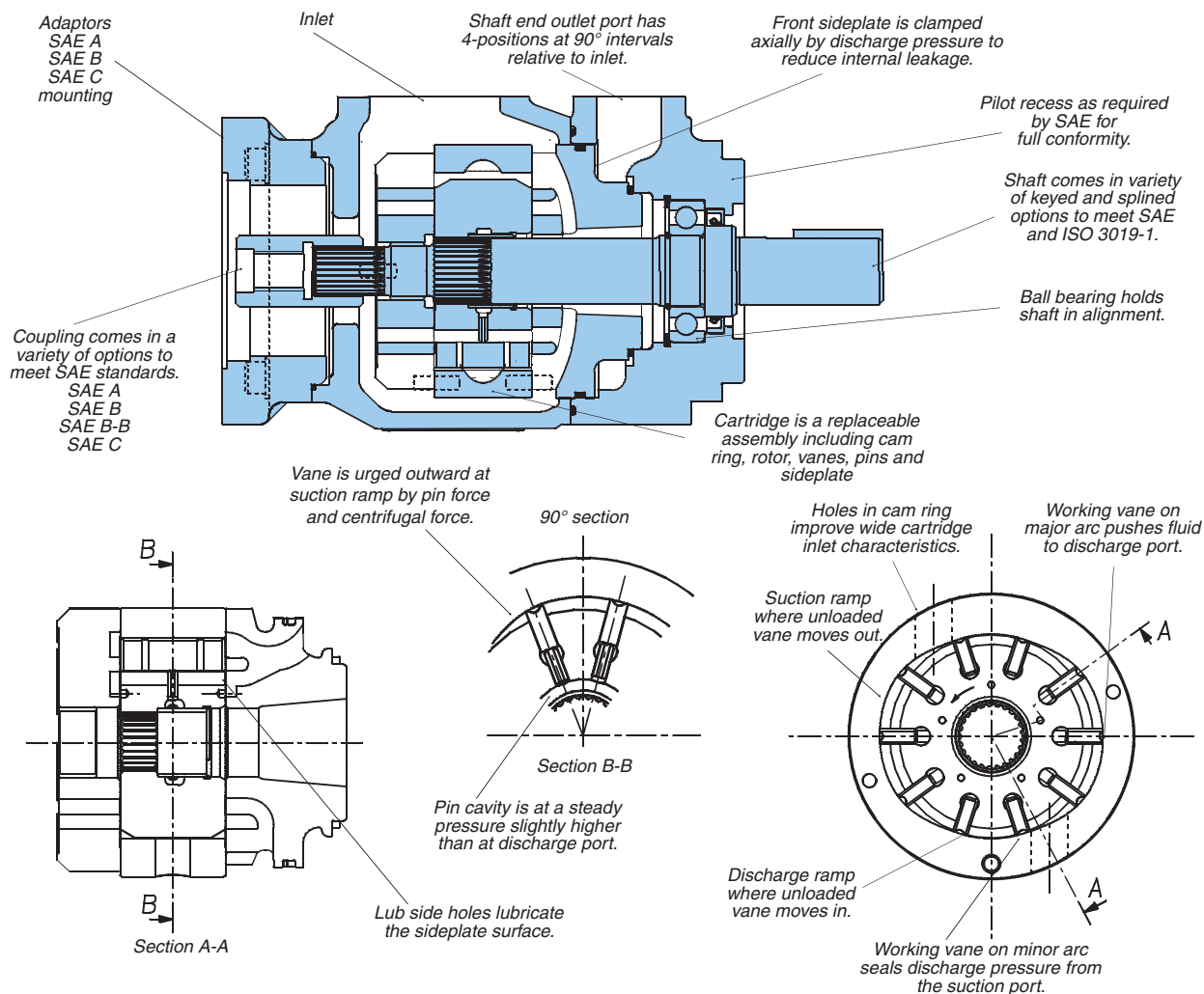

**APPLICATION ADVANTAGES**

- The high pressure capability up to 275 bar, in the small envelope, reduces the installation costs and provides an extended a life at reduced pressure.
- The high volumetric efficiency, typically 94%, reduces the heat generation, and allows speeds down to 400 RPM at full pressure.
- The high mechanical efficiency, typically 94%, reduces the energy consumption.
- The wide speed range from 400 RPM to 2800 RPM, combined with large size cartridge displacements, will optimize operation for the lowest noise level in the smallest envelope.
- The low speed 400 RPM, low pressure, high viscosity 2000 cSt allow applications in cold environments with minimum energy consumption and without seizure risk.
- The low ripple pressure  $\pm 2$  bar reduces the piping noise and increases the life time of other components in the circuit.
- The high resistance to particle contamination because of the double lip vane increases the pump life.
- The large variety of options (cam displacement, shaft, porting) allows customized installation.



**RECOMMENDED FLUIDS**

Petroleum based antiwear R & O fluids.  
 These fluids are the recommended fluids for T6 series pumps. Maximum catalog ratings and performance data are based on operation with these fluids. These fluids are covered by Denison fluid HF-0 and HF-2 specification.

**ACCEPTABLE ALTERNATE FLUIDS**

The use of fluids other than petroleum based antiwear R & O fluids requires that the maximum ratings of the pumps will be reduced. In some cases the minimum replenishment pressures must be increased. Consult specific sections for more details.

**VISCOSITY**

Max (cold start, low speed & pressure) \_\_\_\_\_ 2000 mm<sup>2</sup>/s (cSt)  
 Max (full speed & pressure) \_\_\_\_\_ 108 mm<sup>2</sup>/s (cSt)  
 Optimum (max. life) \_\_\_\_\_ 30 mm<sup>2</sup>/s (cSt)  
 Min (full speed & pressure for HF-1, HF-3, HF-4 & HF-5 fluids) \_\_\_\_\_ 18 mm<sup>2</sup>/s (cSt)  
 Min (full speed & pressure for HF-0 & HF-2 fluids) \_\_\_\_\_ 10 mm<sup>2</sup>/s (cSt)

**VISCOSITY INDEX**

90° min. higher values extend range of operating temperatures.  
 Maximum fluid temperature (θ) °C  
 HF-0, HF-1, HF-2 \_\_\_\_\_ + 100°C  
 HF-3, HF-4 \_\_\_\_\_ + 50°C  
 HF-5 \_\_\_\_\_ + 70°C  
 Biodegradable fluids (esters & rapeseed base) \_\_\_\_\_ + 65°C  
  
 Minimum fluid temperature (θ) °C  
 HF-0, HF-1, HF-2, HF-5 \_\_\_\_\_ - 18°C  
 HF-3, HF-4 \_\_\_\_\_ + 10°C  
 Biodegradable fluids (esters & rapeseed base) \_\_\_\_\_ - 20°C

**FLUID CLEANLINESS**

The fluid must be cleaned before and during operation to maintain the contamination level of NAS 1638 class 8 (or ISO 19/17/14) or better. Filters with 25 micron (or better, β10 ≥ 100) nominal ratings may be adequate but do not guarantee the required cleanliness levels. Suction strainers must be of adequate size to provide the minimum inlet pressure specified. 100 mesh (150 micron) is the finest mesh recommended. Use oversize strainers or omit them altogether on applications which require cold starts or use fire resistant fluids.

**OPERATING TEMPERATURES AND VISCOSITIES**

Operating temperatures are a function of fluid viscosities, fluid type, and the pump. Fluid viscosity should be selected to provide the optimum viscosity at normal operating temperatures. For cold starts, the pumps should be operated at low speed and pressure until the fluid warms up to an acceptable viscosity for full power operation.

**WATER CONTAMINATION IN THE FLUID**

Maximum acceptable content of water.  
 • 0.10% for mineral base fluids.  
 • 0.05% for synthetic fluids, crankcase oils, biodegradable fluids.  
 If amount of water is higher then it should be drained off the circuit.

**COUPLINGS AND FEMALE SPLINES SPLINES**

- The mating female spline should be free to float and find its own center. If both members are rigidly supported, they must be aligned within 0,15 TIR or less to reduce fretting. The angular alignment of two spline axes must be less than ± 0.05 per 25.4 radius..
- The coupling spline must be lubricated with a lithium molydisulfide grease or a similar lubricant.
- The coupling must be hardened to a hardness between 27 and 45 R.C.
- The female spline must be made to conform to the Class 1 fit as described in SAE-J498b (1971). This is described as a Flat Root Side Fit.

**KEYED SHAFTS**

Parker supplies the T6 series keyed shaft pumps with high strength heat-treated keys. Therefore, when installing or replacing these pumps, the heat-treated keys must be used in order to insure maximum life in the application. If the key is replaced, it must be a heat-treated key between 27 and 34 R.C. hardness. The corners of the keys must be chamfered from 0,76 to 1,02 at 45° to clear the radii in the key way.

**NOTE**

The alignment of keyed shafts must be within the tolerances given for splined shafts.

**SHAFT LOADS**

These products are primarily designed for coaxial drives which do not impose axial or side loading on the shaft. Consult specific sections for more details.

**Model No.** T6CRM - B22 - 1 R 00 - A 1 0 - A 1 ..

**Series**

**Cam ring**

(Delivery at 0 bar & 1500 r.p.m.)

B03 = 16,2 l/min	B17 = 87,4 l/min
B05 = 25,8 l/min	B20 = 95,7 l/min
B06 = 31,9 l/min	B22 = 105,4 l/min
B08 = 39,6 l/min	B25 = 118,9 l/min
B10 = 51,1 l/min	B28 = 133,2 l/min
B12 = 55,6 l/min	B31 = 150,0 l/min
B14 = 69,0 l/min	

**Type of shaft**

- 1 = keyed (SAE BB)
- 2 = keyed (non SAE)
- 3 = splined (SAE B)
- 4 = splined (SAE BB)
- 5 = keyed (non SAE)

**Direct. of rotation (view on shaft end)**

- R = clockwise
- L = counter-clockwise

**Porting combination**

00 = standard

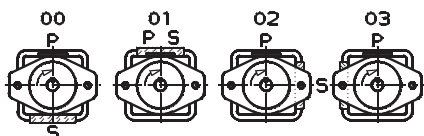

**Modification**

**Seal class**

- 1 = S1 (for mineral oil)
- 4 = S4 (for the resistant fluids)
- 5 = S5 (for mineral oil and fire resistant fluids)

**Design letter**

**Porting adaptor**

**Coupling**

- 1 = SAE A
- 2 = SAE B
- 3 = SAE BB
- 4 = SAE C
- 5 = SAE J498b
- 16/32 - 11 teeth

**Adaptor**

- 0 = None
- A = SAE A
- B = SAE B
- C = SAE C

*Porting adaptor*

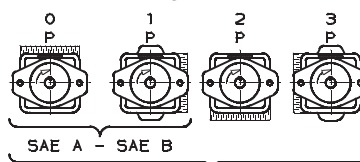

**INTERNAL LEAKAGE (TYPICAL)**

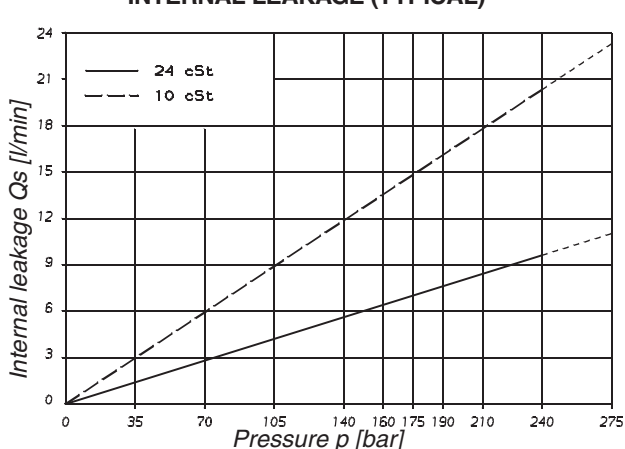

**NOISE LEVEL (TYPICAL)**  
T6CRM - B22

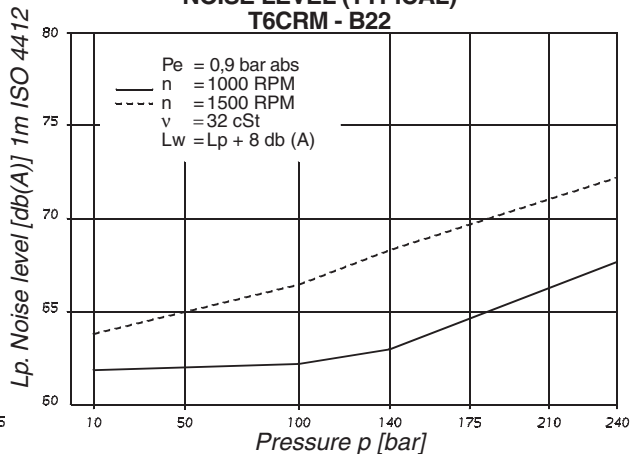

Do not operate the pump more than 5 seconds at any speed or viscosity if internal leakage is more than 50% of theoretical flow.

**POWER LOSS HYDROMECHANICAL (TYPICAL)**

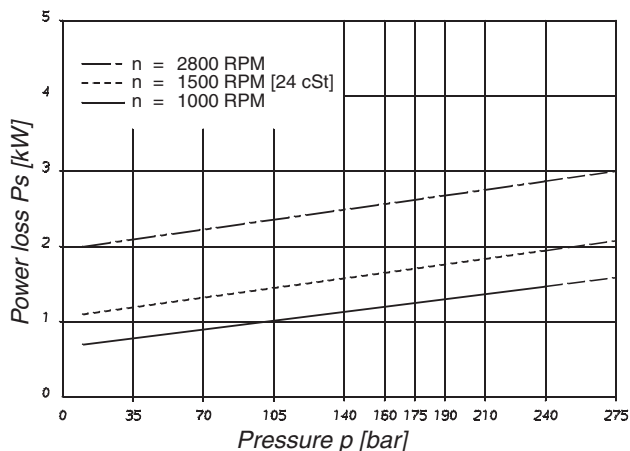

**PERMISSIBLE RADIAL LOAD**

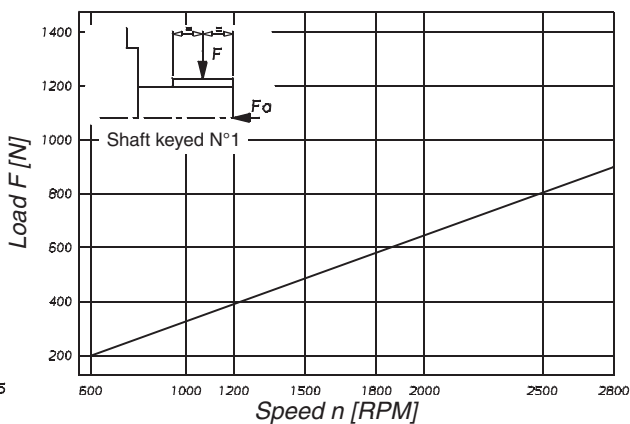

Maximum permissible axial load Fa = 800 N

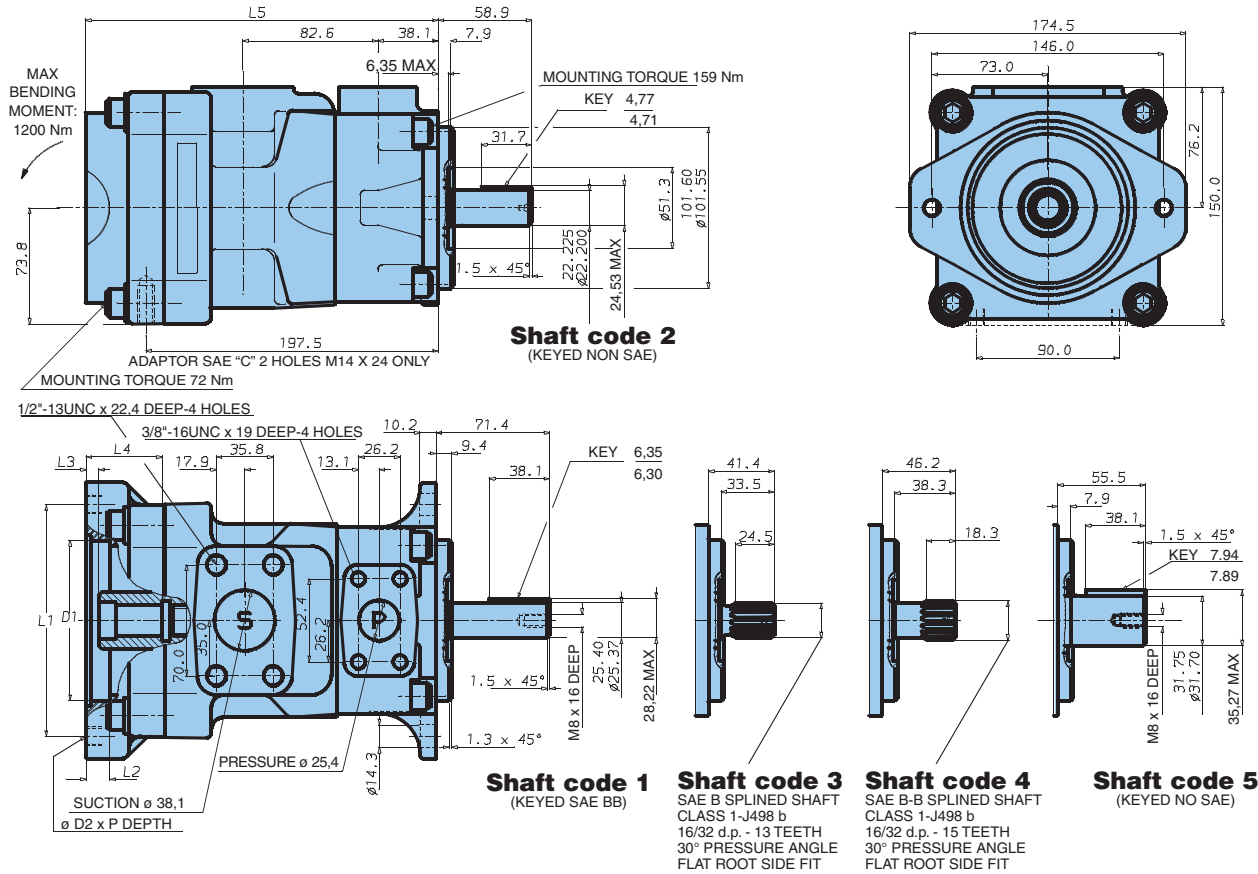

Adaptor	D1	D2	P	L1	L2	L3	L4	L5
SAE A	82,65/82,60	M10	24	106,4	11,0	8,0	32,0	209,0
SAE B	101,70/101,65	M12	28	146,0	16,0	8,0	46,0	223,0
SAE C	127,10/127,05	M16	-	181,0	16,0	8,0	56,0	233,0

Weight 20.4 kg

Adaptor	SAE A			SAE B		SAE C
Coupling drive	SAE A	SAE 11 teeth	SAE B	SAE B	SAE BB	SAE C
Number of teeth	9	11	13	13	15	14
Pitch	16/32	16/32	16/32	16/32	16/32	12/24
Pressure angle	30°	30°	30°	30°	30°	30°
Major dia. (min)	15,875	19,05	22,225	22,225	25,400	31,750
Minor dia. (min)	12,700	16,017	19,134	19,134	22,268	27,589

Shaft torque limits [ml/rev x bar]			
Shaft	Vi x p max.	Coupling drive	Vi x p max.
1	21420	SAE A	11000
2	14300	SAE B	20600
3	20600	SAE BB	22050
4	32670	SAE C	22050
5	34180	SAE - 11 teeth	15850

**OPERATING CHARACTERISTICS - TYPICAL [24 cSt]**

Series	Volumetric Displacement Vi	Flow Q [l/min] & n = 1500 RPM			Input power P [kW] & n = 1500 RPM		
		p = 0 bar	p = 140 bar	p = 240 bar	p = 7 bar	p = 140 bar	p = 240 bar
B03	10,8 ml/rev	16,2	11,2	7,7	1,3	5,3	8,4
B05	17,2 ml/rev	25,8	20,8	17,3	1,4	7,5	12,2
B06	21,3 ml/rev	31,9	26,9	23,4	1,5	8,9	14,7
B08	26,4 ml/rev	51,1	46,1	42,6	1,7	13,4	22,3
B10	34,1 ml/rev	55,6	50,6	47,1	1,7	14,4	24,1
B12	37,1 ml/rev	55,6	50,6	47,1	1,7	14,4	24,1
B14	46,0 ml/rev	69,0	64,0	60,5	1,9	17,6	29,5
B17	58,3 ml/rev	87,4	82,4	78,9	2,1	21,9	36,9
B20	63,8 ml/rev	95,7	90,7	87,2	2,2	23,8	40,2
B22	70,3 ml/rev	105,4	100,4	96,9	2,3	26,1	44,1
B25 <sup>1)</sup>	79,3 ml/rev	118,9	113,9	110,4	2,5	29,2	49,5
B28 <sup>1)</sup>	88,8 ml/rev	133,2	128,2	125,8 <sup>2)</sup>	2,8	32,7	48,5 <sup>2)</sup>
B31 <sup>1)</sup>	100,0 ml/rev	150,0	145,0	142,6 <sup>2)</sup>	2,8	36,5	54,4 <sup>2)</sup>

<sup>1)</sup> B25 - B28 - B31 = 2500 R.P.M. max.    <sup>2)</sup> B28 - B31 = 210 bar max. int.    Port connection can be furnished with metric threads.



Model No. **T6DRM - B45 - 1 R 00 - A 1 0 - A 1 ..**

**Series**

**Cam ring**

(Delivery at 0 bar & 1500 r.p.m.)

B14 = 71,4 l/min	B35 = 166,5 l/min
B17 = 87,3 l/min	B38 = 180,4 l/min
B20 = 99,0 l/min	B42 = 204,0 l/min
B24 = 119,3 l/min	B45 = 218,5 l/min
B28 = 134,5 l/min	B50 = 237,0 l/min
B31 = 147,4 l/min	

**Type of shaft**

- 1 = keyed (SAE C)
- 2 = keyed (SAE CC)
- 3 = splined (SAE C)
- 5 = keyed (non SAE)

**Direct. of rotation (view on shaft end)**

- R = clockwise
- L = counter-clockwise

**Porting combination**

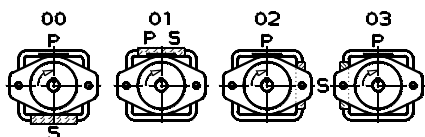

**Modification**

**Seal class**

- 1 = S1 (for mineral oil)
- 4 = S4 (for the resistant fluids)
- 5 = S5 (for mineral oil and fire resistant fluids)

**Design letter**

**Porting adaptor**

**Coupling**

- 1 = SAE A
- 2 = SAE B
- 3 = SAE BB
- 4 = SAE C
- 5 = SAE J498b
- 16/32 - 11 teeth

**Adaptor**

- 0 = None
- A = SAE A
- B = SAE B
- C = SAE C

**Porting adaptor**

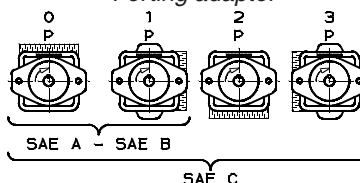

**INTERNAL LEAKAGE (TYPICAL)**

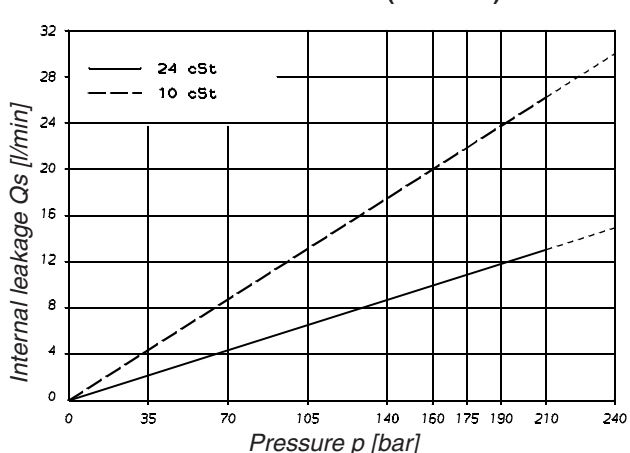

**NOISE LEVEL (TYPICAL)**  
**T6DRM - B38**

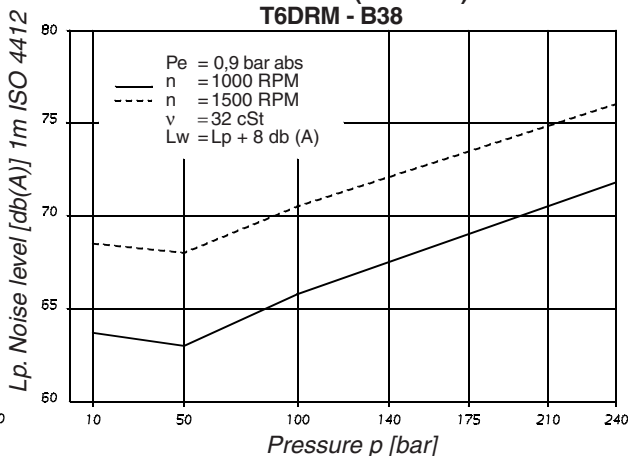

Do not operate the pump more than 5 seconds at any speed or viscosity if internal leakage is more than 50% of theoretical flow.

**POWER LOSS HYDROMECHANICAL (TYPICAL)**

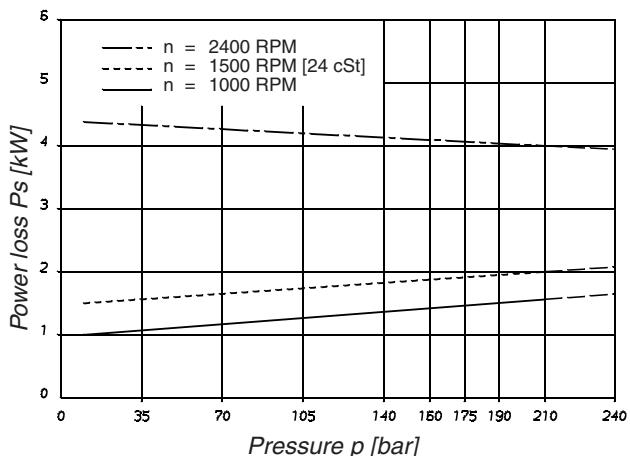

**PERMISSIBLE RADIAL LOAD**

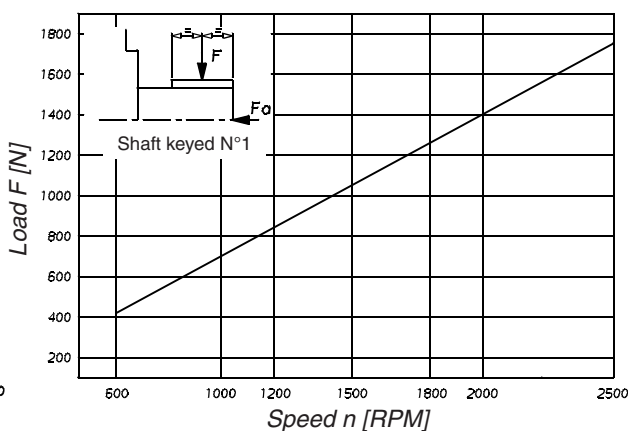

Maximum permissible axial load Fa = 1200 N

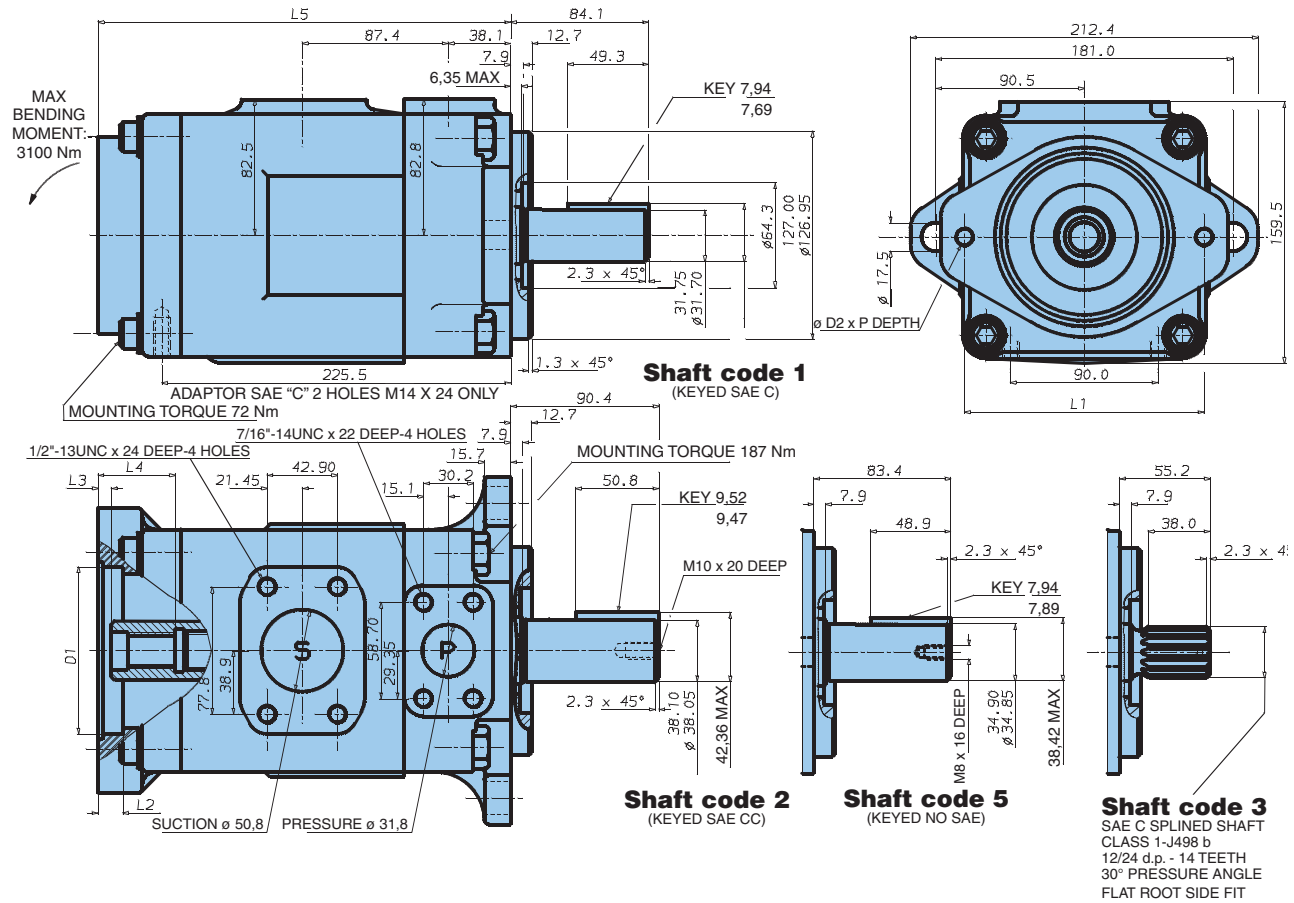

Adaptor	D1	D2	P	L1	L2	L3	L4	L5
SAE A	82,65/82,60	M10	24	106,4	11,0	8,0	32,0	237,0
SAE B	101,70/101,65	M12	28	146,0	16,0	8,0	46,0	251,0
SAE C	127,10/127,05	M16	-	181,0	16,0	8,0	56,0	261,0

Weight 32,3 kg

Adaptor	SAE A			SAE B		SAE C
Coupling drive	SAE A	SAE 11 teeth	SAE B	SAE B	SAE BB	SAE C
Number of teeth	9	11	13	13	15	14
Pitch	16/32	16/32	16/32	16/32	16/32	12/24
Pressure angle	30°	30°	30°	30°	30°	30°
Major dia. (min)	15,875	19,05	22,225	22,225	25,400	31,750
Minor dia. (min)	12,700	16,017	19,134	19,134	22,268	27,589

Shaft torque limits [ml/rev x bar]			
Shaft	Vi x p max.	Coupling drive	Vi x p max.
1	43240	SAE A	11000
2	66036	SAE B	20600
3	61200	SAE BB	32670
5	55600	SAE C	37390
		SAE - 11 teeth	15850

**OPERATING CHARACTERISTICS - TYPICAL [24 cSt]**

Series	Volumetric Displacement Vi	Flow Q [l/min] & n = 1500 RPM			Input power P [kW] & n = 1500 RPM		
		p = 0 bar	p = 140 bar	p = 240 bar	p = 7 bar	p = 140 bar	p = 240 bar
B014	47,6 ml/rev	71,4	62,1	55,9	2,3	18,5	30,6
B017	58,2 ml/rev	87,3	78,0	71,8	2,5	22,2	37,0
B020	66,0 ml/rev	99,0	89,7	83,5	2,8	24,9	41,7
B024	79,5 ml/rev	119,3	110,0	103,8	3,0	29,6	49,8
B028	89,7 ml/rev	134,5	125,2	119,0	3,2	33,2	55,9
B031	98,3 ml/rev	147,4	138,1	131,9	3,3	36,2	61,0
B035	111,0 ml/rev	166,5	157,2	151,0	3,5	40,7	68,7
B038	120,3 ml/rev	180,4	171,1	164,9	3,7	43,9	74,3
B042 <sup>1)</sup>	136,0 ml/rev	204,0	194,7	188,5	4,0	49,4	83,7
B045 <sup>1)</sup>	145,7 ml/rev	218,5	209,2	203,0	4,1	52,8	89,5
B050 <sup>1)</sup>	158,0 ml/rev	237,0	227,7	224,0 <sup>2)</sup>	4,4	57,0	85,0 <sup>2)</sup>

<sup>1)</sup> B42 - B45 - B50 = 2200 R.P.M. max.    <sup>2)</sup> B50 = 210 bar max. int.    Port connection can be furnished with metric threads.

Model No. **T6ERM - 066 - 1 R 00 - A 1 0 - A 1 ..**

**Series**

**Cam ring**

(Delivery at 0 bar & 1500 r.p.m.)

042 = 198,5 l/min      062 = 295,0 l/min

045 = 213,6 l/min      066 = 319,9 l/min

050 = 237,7 l/min      072 = 340,6 l/min

052 = 247,2 l/min

**Type of shaft**

1 = keyed (SAE CC)

3 = splined (SAE C)

4 = splined (SAE CC)

**Direct. of rotation (view on shaft end)**

R = clockwise

L = counter-clockwise

**Porting combination**

**Modification**

**Seal class**

1 = S1 (for mineral oil)

4 = S4 (for the resistant fluids)

5 = S5 (for mineral oil and fire resistant fluids)

**Design letter**

**Porting adaptor**

**Coupling**

1 = SAE A

2 = SAE B

3 = SAE BB

4 = SAE C

5 = SAE J498b

16/32 - 11 teeth

**Adaptor**

0 = None

A = SAE A

B = SAE B

C = SAE C

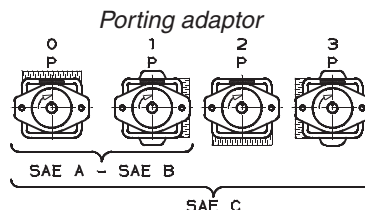
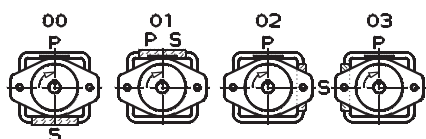

**INTERNAL LEAKAGE (TYPICAL)**

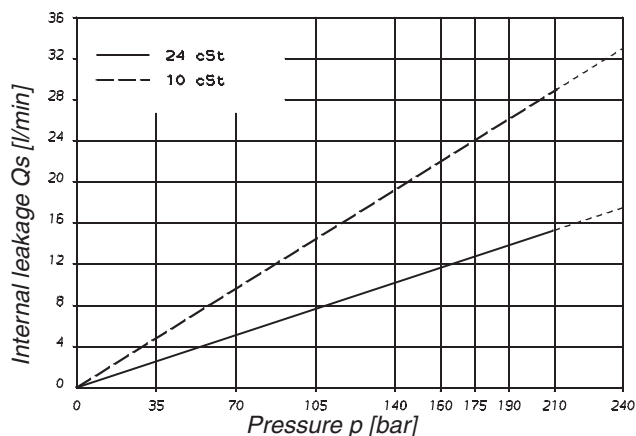

**NOISE LEVEL (TYPICAL)  
T6ERM - 050**

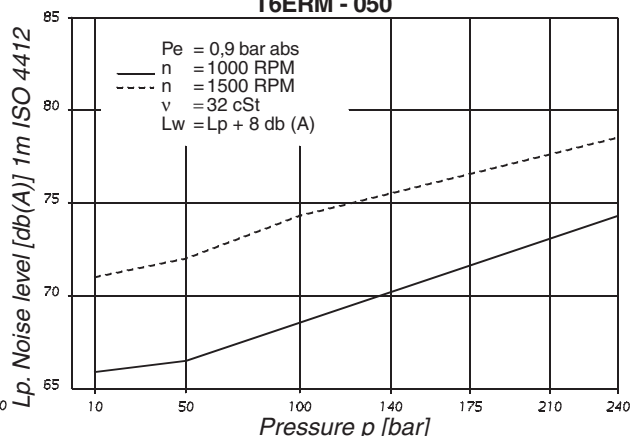

**POWER LOSS HYDROMECHANICAL (TYPICAL)**

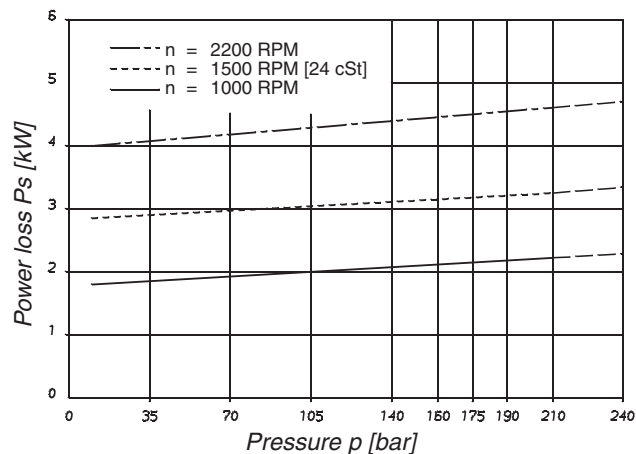

**PERMISSIBLE RADIAL LOAD**

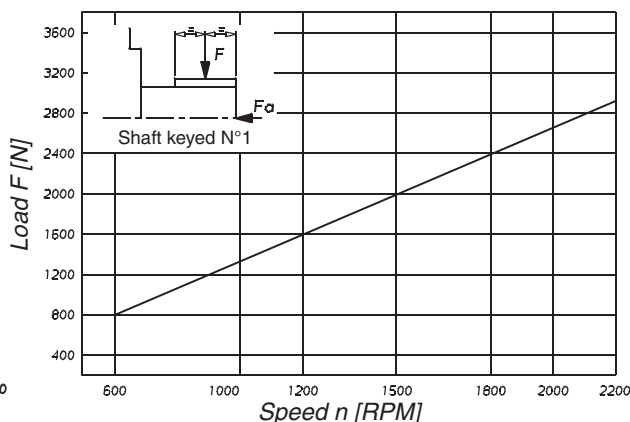

Maximum permissible axial load Fa = 2000 N

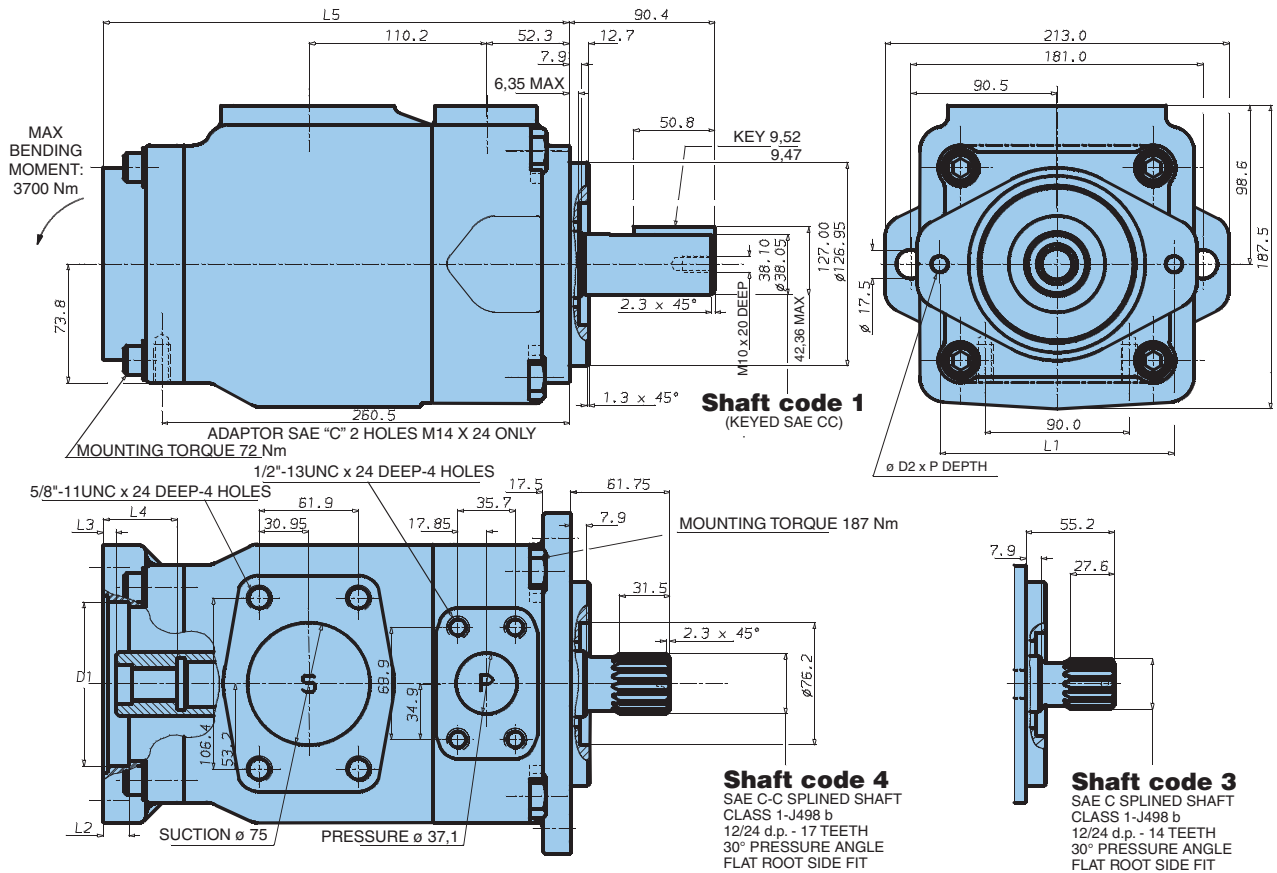

Adaptor	D1	D2	P	L1	L2	L3	L4	L5
SAE A	82,65/82,60	M10	24	106,4	11,0	8,0	32,0	272,0
SAE B	101,70/101,65	M12	28	146,0	16,0	8,0	46,0	286,0
SAE C	127,10/127,05	M16	-	181,0	16,0	8,0	56,0	296,0

Weight 42,5 kg

Adaptor	SAE A			SAE B		SAE C
Coupling drive	SAE A	SAE 11 teeth	SAE B	SAE B	SAE BB	SAE C
Number of teeth	9	11	13	13	15	14
Pitch	16/32	16/32	16/32	16/32	16/32	12/24
Pressure angle	30°	30°	30°	30°	30°	30°
Major dia. (min)	15,875	19,05	22,225	22,225	25,400	31,750
Minor dia. (min)	12,700	16,017	19,134	19,134	22,268	27,589

Shaft torque limits [ml/rev x bar]			
Shaft	Vi x p max.	Coupling drive	Vi x p max.
1	80560	SAE A	11000
3	61200	SAE B	20600
4	120210	SAE BB	32670
		SAE C	66480
		SAE - 11 teeth	15850

**OPERATING CHARACTERISTICS - TYPICAL [24 cSt]**

Series	Volumetric Displacement Vi	Flow Q [l/min] & n = 1500 RPM			Input power P [kW] & n = 1500 RPM		
		p = 0 bar	p = 140 bar	p = 240 bar	p = 7 bar	p = 140 bar	p = 240 bar
042	132,3 ml/rev	198,5	188,5	181,3	5,2	49,4	82,6
045	142,4 ml/rev	213,6	203,6	196,5	5,4	52,9	88,7
050	158,5 ml/rev	237,7	227,7	220,6	5,7	58,5	98,3
052	164,8 ml/rev	247,2	237,2	230,1	5,8	60,8	102,1
062	196,7 ml/rev	295,0	285,0	277,9	6,4	71,9	121,3
066	213,3 ml/rev	319,9	309,9	302,8	6,7	77,7	131,2
072	227,1 ml/rev	340,6	330,6	323,5	6,9	82,6	139,5

Port connection can be furnished with metric threads.

Ass'y Tandem VV - ...

Ass'y Tandem	Porting combination
VV = Vane pump + vane pump	00
VP = Vane pump + Piston pump (PV)	01
VG = Vane pump + Gear pump (GP)	02
VH = Vane pump + Hybrid pump (T6H*)	03

**Assembly screws**

- SAE A rear mounting adaptor : 2 screws M10 x 30 (Mounting torque = 49 Nm.)
- SAE B rear mounting adaptor : 2 screws M12 x 35 (Mounting torque = 88 Nm.)
- SAE C rear mounting adaptor : 2 screws M16 x 40 (Mounting torque = 190 Nm.)

**ASSEMBLY PORTING COMBINATION**

- VV type = Front single vane pump (view from shaft end).

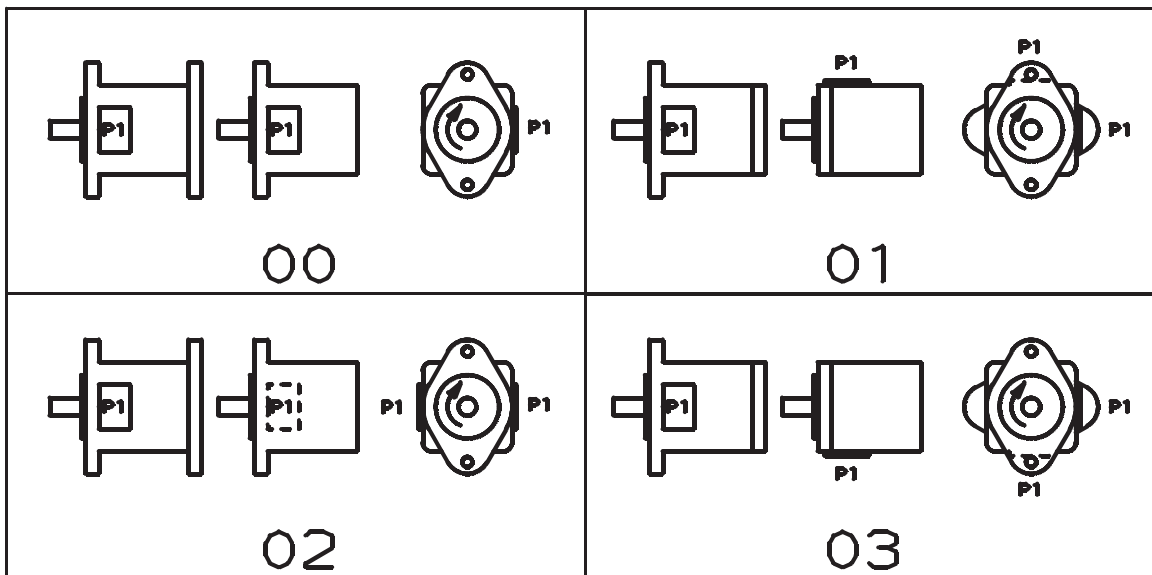

- VV type = For triple vane pump (view from shaft end).

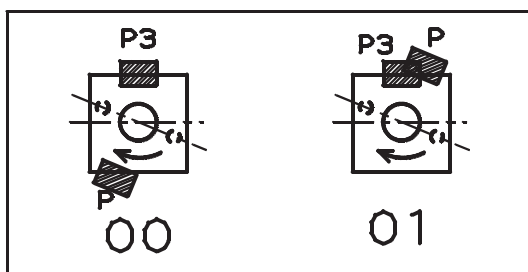



- VP & VH type = For the second pump the reference is the DR drain port on piston pump (view from shaft end).

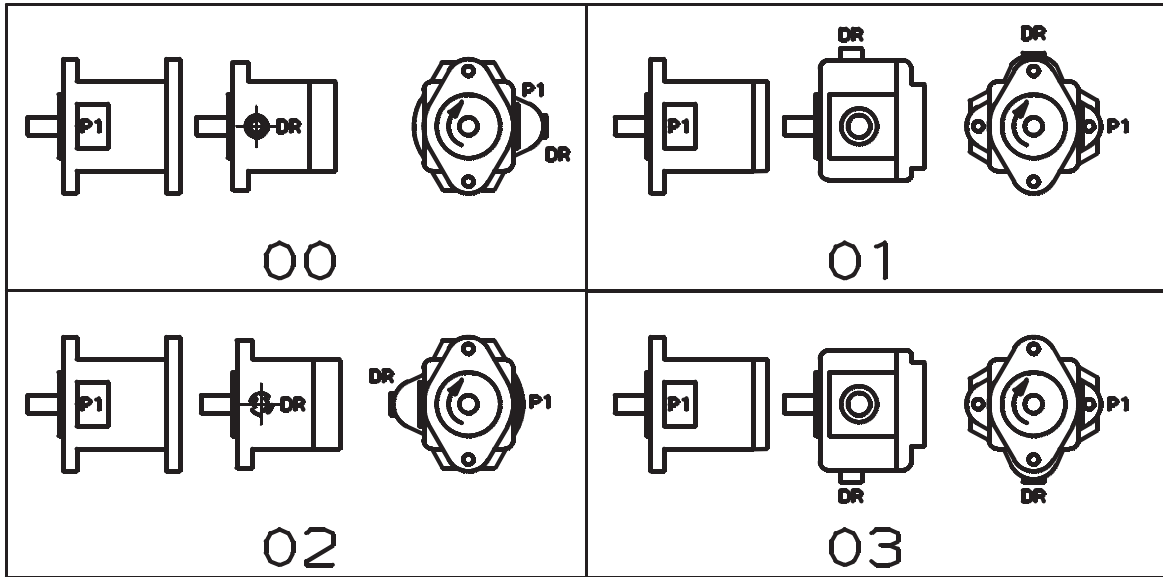

- VG type = For single vane pump (view from shaft end).

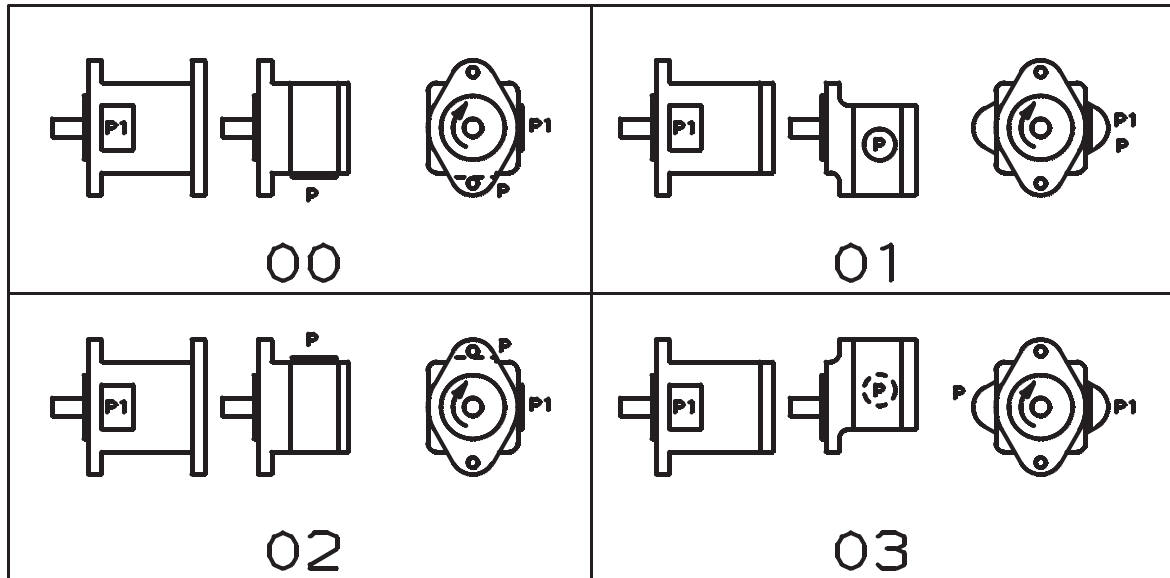

- VG type = For triple vane pump (view from shaft end).

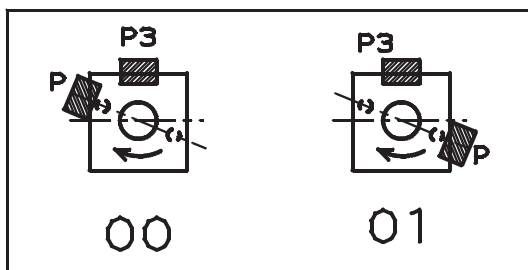

Rear pump		Drive train vane pump			
		T6*R (single pumps)		T6***R (triple pumps)	
Serie	Shaft	Coupling	Adaptor	Coupling	Adaptor
T6C*	3	2	B	Not available	
T6CR*	4	4	B	Not available	
T6CSH					
T6CC*	3	3	B	Not available	
	5	2	B	Not available	
T6D*	3	4	C	Not available	
T6DR*					
T6DC*					
T6DCC*					
T6E*	3	4	C	Not available	
T6ER*					
T6EC*					
T6ED*					
TB	4	1	A	Available	
	3	5	A	Available	
T7B	3	2	B	Not available	
	4	3	B	Not available	
T6H***	4	3	B	Not available	
PV6	1	2	A	Available with special coupling	
PV10	1	2	B	Not available	
PV15					
PV20	1	4	C	Not available	
PV29					
GP1D	3	1	A	Available	
GP2D	3	1	A	Available up to 12 cm <sup>3</sup> /rev.	
GP2A	3	1	A	Available	
GP3A	3	2	B	Not available	

For additional information on Piston or Gear pumps, see the specific bulletins.

**EXAMPLE**

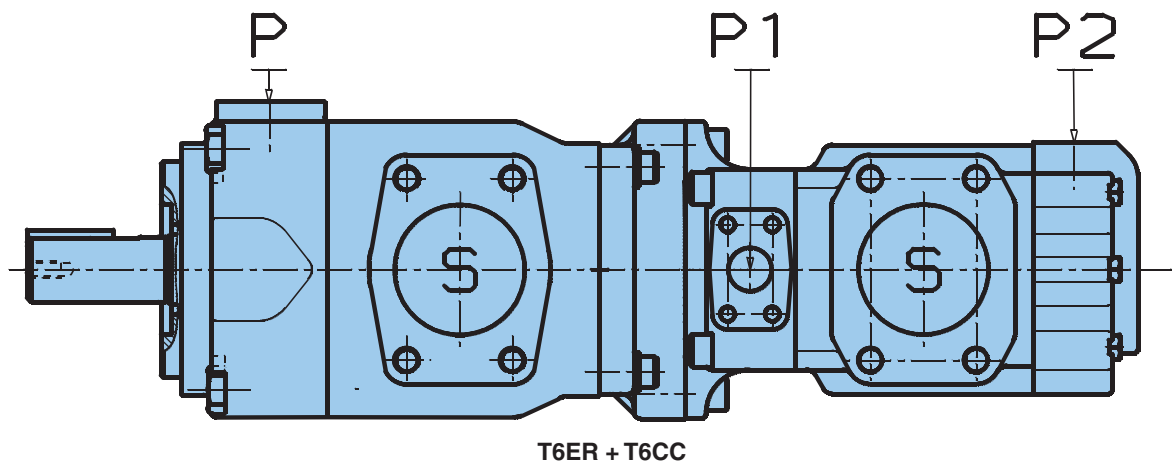

- 1. Define front pump  
T6ER - \*\*\* - 1 R 02 - B21 - A 1
- 2. Define rear pump  
T6CC - \*\*\* - \*\*\* - 5 R 01 - C 100
- 3. Define mounting  
Ass'y tandem VV03

# Parker Worldwide

**AE – UAE, Dubai**  
Tel: +971 4 8127100  
parker.me@parker.com

**AR – Argentina, Buenos Aires**  
Tel: +54 3327 44 4129

**AT – Austria, Wiener Neustadt**  
Tel: +43 (0)2622 23501-0  
parker.austria@parker.com

**AT – Eastern Europe, Wiener Neustadt**  
Tel: +43 (0)2622 23501 900  
parker.easteurope@parker.com

**AU – Australia, Castle Hill**  
Tel: +61 (0)2-9634 7777

**AZ – Azerbaijan, Baku**  
Tel: +994 50 2233 458  
parker.azerbaijan@parker.com

**BE/LU – Belgium, Nivelles**  
Tel: +32 (0)67 280 900  
parker.belgium@parker.com

**BR – Brazil, Cachoeirinha RS**  
Tel: +55 51 3470 9144

**BY – Belarus, Minsk**  
Tel: +375 17 209 9399  
parker.belarus@parker.com

**CA – Canada, Milton, Ontario**  
Tel: +1 905 693 3000

**CH – Switzerland, Etoy**  
Tel: +41 (0) 21 821 02 30  
parker.switzerland@parker.com

**CL – Chile, Santiago**  
Tel: +56 2 623 1216

**CN – China, Shanghai**  
Tel: +86 21 2899 5000

**CZ – Czech Republic, Klecany**  
Tel: +420 284 083 111  
parker.czechrepublic@parker.com

**DE – Germany, Kaarst**  
Tel: +49 (0)2131 4016 0  
parker.germany@parker.com

**DK – Denmark, Ballerup**  
Tel: +45 43 56 04 00  
parker.denmark@parker.com

**ES – Spain, Madrid**  
Tel: +34 902 330 001  
parker.spain@parker.com

**FI – Finland, Vantaa**  
Tel: +358 (0)20 753 2500  
parker.finland@parker.com

**FR – France, Contamine s/Arve**  
Tel: +33 (0)4 50 25 80 25  
parker.france@parker.com

**GR – Greece, Athens**  
Tel: +30 210 933 6450  
parker.greece@parker.com

**HK – Hong Kong**  
Tel: +852 2428 8008

**HU – Hungary, Budapest**  
Tel: +36 1 220 4155  
parker.hungary@parker.com

**IE – Ireland, Dublin**  
Tel: +353 (0)1 466 6370  
parker.ireland@parker.com

**IN – India, Mumbai**  
Tel: +91 22 6513 7081-85

**IT – Italy, Corsico (MI)**  
Tel: +39 02 45 19 21  
parker.italy@parker.com

**JP – Japan, Fujisawa**  
Tel: +(81) 4 6635 3050

**KR – South Korea, Seoul**  
Tel: +82 2 559 0400

**KZ – Kazakhstan, Almaty**  
Tel: +7 7272 505 800  
parker.easteurope@parker.com

**LV – Latvia, Riga**  
Tel: +371 6 745 2601  
parker.latvia@parker.com

**MX – Mexico, Apodaca**  
Tel: +52 81 8156 6000

**MY – Malaysia, Shah Alam**  
Tel: +60 3 7849 0800

**NL – The Netherlands, Oldenzaal**  
Tel: +31 (0)541 585 000  
parker.nl@parker.com

**NO – Norway, Ski**  
Tel: +47 64 91 10 00  
parker.norway@parker.com

**NZ – New Zealand, Mt Wellington**  
Tel: +64 9 574 1744

**PL – Poland, Warsaw**  
Tel: +48 (0)22 573 24 00  
parker.poland@parker.com

**PT – Portugal, Leca da Palmeira**  
Tel: +351 22 999 7360  
parker.portugal@parker.com

**RO – Romania, Bucharest**  
Tel: +40 21 252 1382  
parker.romania@parker.com

**RU – Russia, Moscow**  
Tel: +7 495 645-2156  
parker.russia@parker.com

**SE – Sweden, Spånga**  
Tel: +46 (0)8 59 79 50 00  
parker.sweden@parker.com

**SG – Singapore**  
Tel: +65 6887 6300

**SK – Slovakia, Banská Bystrica**  
Tel: +421 484 162 252  
parker.slovakia@parker.com

**SL – Slovenia, Novo Mesto**  
Tel: +386 7 337 6650  
parker.slovenia@parker.com

**TH – Thailand, Bangkok**  
Tel: +662 717 8140

**TR – Turkey, Istanbul**  
Tel: +90 216 4997081  
parker.turkey@parker.com

**TW – Taiwan, Taipei**  
Tel: +886 2 2298 8987

**UA – Ukraine, Kiev**  
Tel: +380 44 494 2731  
parker.ukraine@parker.com

**UK – United Kingdom, Warwick**  
Tel: +44 (0)1926 317 878  
parker.uk@parker.com

**US – USA, Cleveland (industrial)**  
Tel: +1 216 896 3000

**US – USA, Lincolnshire (mobile)**  
Tel: +1 847 821 1500

**VE – Venezuela, Caracas**  
Tel: +58 212 238 5422

**ZA – South Africa, Kempton Park**  
Tel: +27 (0)11 961 0700  
parker.southafrica@parker.com

**European Product Information Centre**  
Free phone: 00 800 27 27 5374  
(from AT, BE, CH, CZ, DE, DK, EE, ES, FI, FR, IE, IL, IS, IT, LU, MT, NL, NO, PL, PT, RU, SE, UK, ZA)



**Parker Hannifin Ltd.**  
Tachbrook Park Drive  
Tachbrook Park, Warwick CV34 6TU  
United Kingdom  
Tel.: +44 (0) 1926 317 878  
Fax: +44 (0) 1926 317 855  
www.parker.com